

# INSTRUCTION AND MAINTENANCE MANUAL

**TB AM**  
**ATEX Z22 II3D**

## GENERAL INSTRUCTIONS

# INDEX:

1.	INFORMATIVE SECTION.....	4
1.1	Foreword.....	4
1.2	Main components .....	7
1.3	Optional parts .....	8
1.4	Manufacturer's identification data .....	8
1.5	Identification plate .....	9
1.6	Atex marking.....	9
1.7	Permitted Uses .....	10
1.8	Authorised environmental conditions.....	10
1.9	Noise level .....	10
1.10	Technical data .....	11
1.11	Warranty .....	12
2	SAFETY SECTION .....	13
2.1	Safety informations .....	13
2.2	Safety recommendations .....	14
2.3	Safety plates and symbols.....	17
2.4	Residual risks .....	18
2.5	Applied Directives .....	19
2.6	ATEX safety instructions.....	19
3.	HANDLING, UNPACKING AND INSTALLATION SECTION .....	25
3.1	Handling.....	25
3.2	Unpacking.....	26
3.3	Installation.....	27
4.	OPERATION SECTION .....	28
4.1	Description of the controls .....	28
4.3	Emptying the bin .....	29
4.4	Inserting and locking the bin .....	31
4.5	Storage – Decommissioning .....	32
5.	MAINTENANCE SECTION .....	32
5.1	Informative notes .....	32
5.2	General safety regulations.....	33
5.3	Replacing the filter .....	35
5.4	Troubleshooting .....	38
5.5	Scrapping.....	38

## DECLARATION OF COMPLIANCE

The manufacturer:

**DEPURECO INDUSTRIAL VACUUMS S.r.l.** – Via Venezia, 32 – 10088 Volpiano (TO) – ITALY |  
**Phone.** +39 011 98 59 117 – **Fax** + 39 011 98 59 326 – **Tax code.** | **VAT REG. NO.**  
02258610357

**e-mail:** [depureco@depureco.com](mailto:depureco@depureco.com) – [www.depureco.com](http://www.depureco.com)

hereby declares

under their sole responsibility that the vacuum cleaner model described in this manual



To which this declaration refers, complies with the essential safety requirements provided by the **Machinery Directive 2006/42/EC**, the **Directive 2014/30/EU** regarding Electromagnetic Compatibility, the **Directive 2011/65/EU - ROHS** - regarding restriction of the use of certain hazardous substances in electrical and electronic appliances and by the **ATEX Directive 2014/34/EU** with the following details.

The conformity has been verified in accordance with the requirements mentioned by the Standards:

**UNI EN 1127-1:2019**

**UNI EN ISO 80079-36:2016**

**EN 60079-0:2018**

**EN60079-31:2014**

marking: **CE** **Ex** **II 3 D Ex htc IIIC T140°C Dc**

The Harmonised Standards applied for the design, manufacture and testing of the vacuum cleaner are listed in a technical file stored at the technical department of DEPURECO S.r.l. premises.

This declaration shall become invalid if modifications on the vacuum cleaner are carried out without approval from the manufacturer.

First issue: 15 June 2019

Revision 01: 16 October 2023.



The Legal Representative  
Marco Devinentis CEO

## 1. INFORMATIVE SECTION



This manual forms an integral part of the vacuum cleaner. Read this manual and the other attachments supplied carefully. Knowledge of the instructions here contained is indispensable for the safe use and maintenance of the vacuum cleaner

**IMPORTANT - The DEPURECO term and logo in this document refer to and are the property of DEPURECO INDUSTRIAL VACUUMS S.r.l.**

This document remains the exclusive property of DEPURECO S.r.l. Full or partial reproduction by any means (graphical, electronic, etc.) is prohibited without prior authorisation from the Company Management.

### 1.1 Foreword

Dear Customer

Thank you for having chosen DEPURECO; we hope you will enjoy using your new DEPURECO ECOBULL series vacuum cleaner. This manual has been drafted in order for our customer to fully appreciate the quality of this machine. Please read all sections before using the machine for the first time.

It includes information, recommendations and important warnings concerning the use of the vacuum, which will help fully exploit the technical properties of your machine.

Read messages, warnings and indications preceded by the following symbols carefully:



**For the safety of people**



**For the integrity of the vacuum cleaner**



**For the safeguard of the environment**

This manual describes the following models:

**Conductive dust extractor**

The aspirator is equipped with the following filter:

- ❑ CONICAL FILTER CARTRIDGE CLASS H ANTISTATIC (P12720))

**The vacuums are classified according to the following dust classes:**

**L** Low risk – suitable to separate dust with an exposure limit value of  $> 1 \text{ mg/m}^3$  on the basis of the occupied volume

**M** Medium risk - suitable to separate dust with an exposure limit value of  $> 0,1 \text{ mg/m}^3$  on the basis of the occupied volume

**H** High risk – suitable to separate all dusts with all exposure limit values on the basis of the occupied volume, including cancerogenic and pathogenic dusts.

This manual provides all the necessary information for the use and maintenance of the vacuum cleaner.

This specific model has undergone strict testing to ensure maximum reliability. Its operation and durability will depend on proper use and maintenance.

This manual is an integral part of the vacuum cleaner and must accompany it at all times, until its demolition.

In the event it is lost or damaged, you can request another copy from DEPURECO INDUSTRIAL VACUUMS S.r.l. (henceforth shortened to DEPURECO).

The technical information contained in this manual is exclusive property of DEPURECO and must be considered confidential.

Reproduction, even partial, of graphics, text and illustrations is prohibited by law.

Some details shown in the figures in this manual may differ from those on your vacuum; this is because some components may have been removed to ensure maximum illustration clarity.

This manual has been divided into sections for easy consultation and each section has been identified by a specific graphical symbol.

The topics covered in this manual are those expressly required by Machinery Directive 2006/42/EC and the technical data are taken from the technical file archived at DEPURECO.

With reference to Regulation 1907/2006/EC (REACH), DEPURECO hereby declares that no Substances of *Very High Concern* - (SVHC) included in the Candidate List, are contained in its products.

This manual should be kept in a place accessible to all personnel in charge with operating and performing maintenance on the vacuum cleaner.

In the event of any dispute arising, the Court of Turin (Italy) shall have jurisdiction



This manual forms an integral part of the vacuum cleaner. Read this manual and the other attachments supplied carefully. Knowledge of the instructions here contained is indispensable for the safe use and maintenance of the vacuum cleaner

## 1.2 Main components

- 1) Blower
- 2) Motor base
- 3) Vacuum gauge
- 4) Silencer
- 5) On / off selector
- 6) Filter chamber
- 7) Suction inlet
- 8) Dust / debris collection container
- 9) Porthole of maximum level
- 10) Fixed frame
- 11) Hydrogen Safety valve
- 12) Discharge valve
- 13) Safety valve
- 14) Handle
- 15) Handle for container extraction and transport
- 16) Diffuser filter

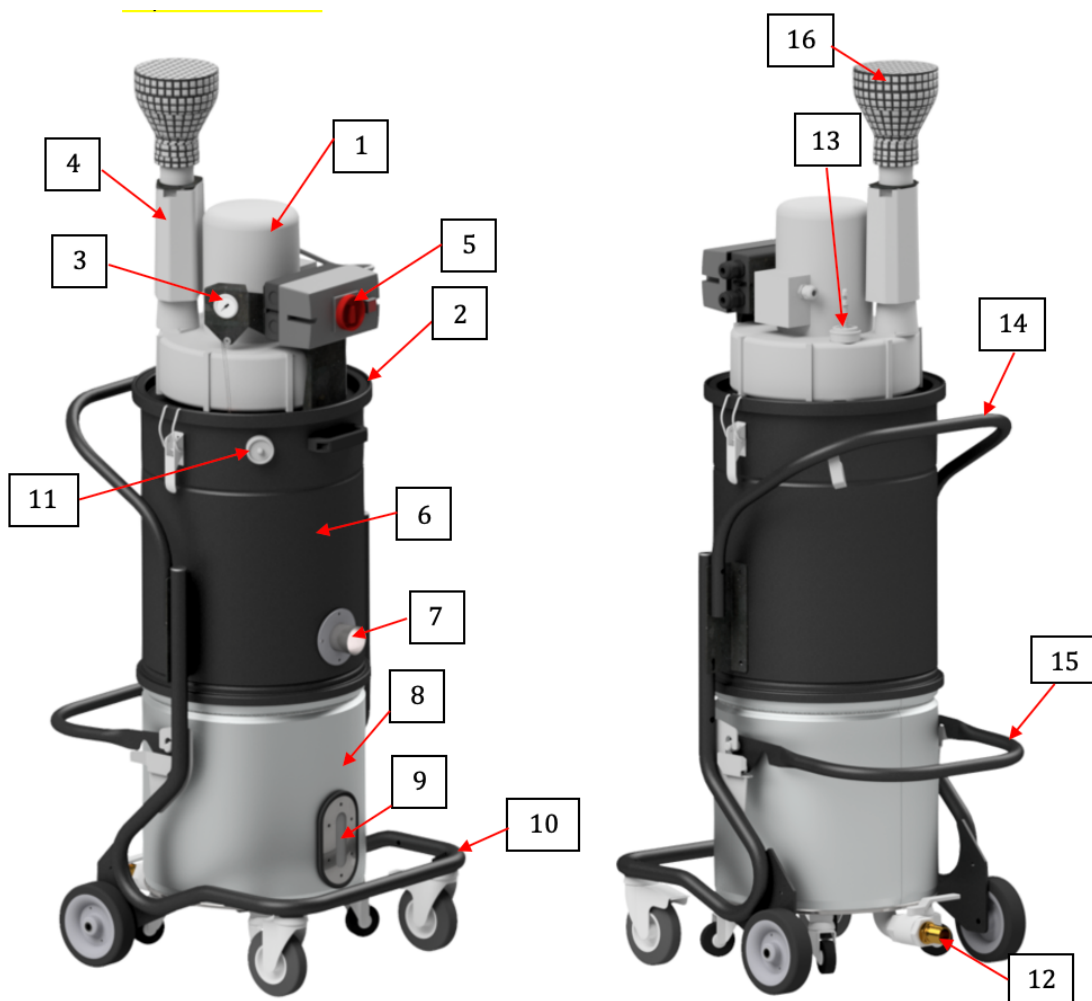

## ATTENTION!

There are two adhesive labels on the container.

The sticker near the inspection window [A] indicates the maximum level of inerting liquid admissible inside the container.

The stickers depicting an arrow [B] have the function of indicating to the operator the correct positioning of the filter unit for oils with respect to the container.

NOTE Use only inerting liquid compatible with the use for which the vacuum cleaner was manufactured.

DEPURECO declines all responsibility for the use of non-compliant and unsuitable inerting liquid for the purpose for which the vacuum cleaner was designed.



It is possible to lift the container only when the filter unit is correctly positioned.

## SAFETY VALVE

In the machine chamber there is a safety valve [12] that allows gas to escape if it accumulates inside the machine.

## CONTAINER

Inside the container there are the following components:

- A grilled basket
- A washable bag filter

The filter has the function of separating the solid parts from the inerting oil

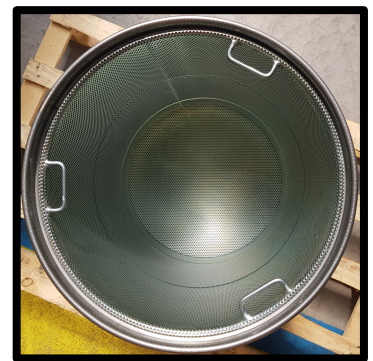

### 1.3 Optional parts

Depending on the application of the vacuum cleaner, a wide range of other optional accessories is available from DEPURECO.

### 1.4 Manufacturer's identification data

DEPURECO INDUSTRIAL VACUUMS S.r.l.  
Via Venezia 32 - 10088 Volpiano (TO) - ITALY  
tel. +39 011 98 59 117 - fax +39 011 98 59 326 | P.I. 02258610357  
e-mail: [depureco@depureco.com](mailto:depureco@depureco.com) - website: [www.depureco.com](http://www.depureco.com)



## 1.5 Identification plate

The data on the vacuum identification plate must be referred to in any correspondence with the manufacturer or the dealer.

 <b>DEPURECO</b>		Via Venezia, 32, 10088, Volpiano Tel. 011 98 59 117   Fax. 011 98 59 326 www.depureco.com		
Model		Serial No.		 
Dust class	IP	Kg	Year	

## 1.6 Atex marking

Marking for luminaire suitable for use in an outdoor area classified as ZONE 22:

<b>Manufacturer .....</b>
<b>Street address .....</b>
<b>Device ...</b>
<b>Serial n. ....</b>
<b>CE II 3 D Ex htc IIIC T140 ° C Dc</b> <b>-15 ° C ≤ Tamb ≤ + 40 ° C</b>
Year: 2021
Other data (flow rate etc.)



**ATEX marking only valid when using silicone-based inertising oil with high dielectric strength (approx. 1014 Ohm cm)**

## 1.7 Permitted Uses

These vacuum cleaners are built and designed in accordance with Directive 2006/42 / EC (Machinery Directive) for an exclusive professional industrial use; however, for purposes other than normal domestic purposes.



**This vacuum cleaner is designed to collect combustible dust and / or dry particles in atmospheres classified as Zone 22 (valid for atex vacuum cleaners), with the following limitations:  
Minimum ignition energy (MIE) of the dust > 3mJ**

The vacuum cleaner was conceived to be used by only one operator.

In accordance with the Directive 1999/92/EC, whenever in the presence of combustible dust and/or flammable gas, it's the responsibility of the employer to carry out the classification of the Zone and to choose a device in the appropriate category (According to the definition given in the 2014/34/EU Directive.

Any other use is considered **IMPROPER**.

## 1.8 Authorised environmental conditions

To ensure the correct operation, the vacuum cleaner must be kept away from atmospheric agents (rain, hail, snow, fog, dust in suspension, etc.) in an area with a room temperature range between 5° and 45°C and a relative humidity no higher than 70%.

The work environment must be clean and suitably lit.

## 1.9 Noise level

The phonometric tests performed on this specific vacuum cleaner model demonstrate a sound pressure level of

**72 dB(A)**



### **WARNING!**

Workers exposed to sound pressure levels higher than 85 dB(A) must be protected by suitable personal protection device (PPE) such as certified ear muffs.

**Under these conditions, workers must be provided with adequate training and information on risks arising from noise exposure.**

## 1.10 Technical data

	<b>U.M.</b>	<b>TB AM</b>
Weight*	[Kg]	50
Height	[mm]	1400
Dimensions**	[mm]	550x620
Voltage/ Frequency	[V]- [Hz]	400   50-60
Power	[kW -HP]	1,8 – 2,4
Depression in continuous run	[mBar]	180
Max. Air flow	[m <sup>3</sup> /h]	240
Primary filter	Conical cartridge H13	
Filter surface	[cm <sup>2</sup> ]	35.000
Noise level	[dB-A]	72
Bin capacity	[L]	45

(\*) weight without packaging - packaging weight = 20 Kg

(\*\*) machine dimensions without packaging

## 1.11 Warranty

DEPURECO guarantees this model of vacuum cleaner for a period of 24 months from the date of purchase, indicated on the receipt at the time of delivery of the product.

The guarantee is null and void in the event that the vacuum is repaired by unauthorised third parties or by using equipment, accessories or components not supplied or not authorised by DEPURECO, or if the serial number is removed (during the guarantee period).

For the duration of the guarantee, DEPURECO undertakes to repair or replace free of charge parts and components which prove to have manufacturing defects. Repairs will be exclusively executed at a DEPURECO site or in a DEPURECO approved Assistance Centre and the machine must be sent free of charge (freight cost at user's charge unless otherwise agreed).

The guarantee does not cover cleaning of working parts. The purchase invoice must be shown to the authorised technical personnel carrying out the repair and must accompany the vacuum during its shipment.

Defects that are not evidently due to materials or manufacturing will be examined solely at our premises or at a Technical Service Centre of our choosing. Should the complaint be unjustified, all repair and/or replacement expenses shall be charged to the purchaser.

In any case, the following items are not covered by the guarantee: accidental damage due to transport, negligence, abnormal use, improper use, non-compliance with the instructions contained in this booklet or arising from phenomena that do not depend on normal use/operation of the vacuum.

DEPURECO shall not be held liable for any injuries to persons or damage to objects caused by misuse or improper use of the vacuum.

In the event of any dispute arising, the Court of Turin (Italy) shall have jurisdiction.



To use the warranty, visit [www.depureco.com](http://www.depureco.com) or photocopy the form available on the last page of this manual, fill it in all its parts (in capital letters would be recommended), and send it via fax to Depureco at the number **+ 39 011 98 59 117**



In the event of doubts, avoid interpreting the information! Call your reseller immediately!

## 2 SAFETY SECTION

### 2.1 Safety informations



As per Italian Legislative Decree 81/08 and subsequent modifications, the Safety Manager must train and inform workers about the risks involved with using the vacuum cleaner so that they may be able to avoid injury to themselves and others.

The use of device by people (including children) with limited physical and mental capacities or lacking in experience and knowledge is strictly forbidden, unless they are supervised by a person who is experienced in the use and safe handling of the device. Children must be supervised to make sure they will not play with the device.

Failure to comply norms, laws or basic safety precautions, may cause accidents during operation, maintenance and repair of the vacuum cleaner. Accidents can frequently be avoided by recognising potentially hazardous situations before they occur. Adequate training is crucial to this end.

DEPURECO shall not be held liable for accidents or damage due to the improper use of the vacuum by untrained personnel or to failure to comply, even partially, with the occupational safety standards and intervention procedures contained in this manual.

Safety warnings and precautions are indicated in this manual as well as on the product itself.

Operators must pay special attention to these hazard warnings to prevent accidents with serious consequences for themselves and other people.

The safety warnings are indicated by the following symbols:

DEPURECO designs and manufactures its equipment and accessories with care, identifying and compensating possible risks related to their use. In the event of equipment, procedures, work methods or techniques not expressly provided for by DEPURECO being used, it is crucial to ensure beforehand that there are no dangers for oneself and the others. Nevertheless, DEPURECO shall not be held liable.

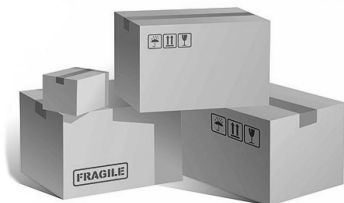

#### **Use exclusively Depureco original spare parts.**

Depureco disclaims any liability in case spare parts other than original have been used.

## 2.2 Safety recommendations



### **WARNING!**

The following information is essential in view of preventing all hazards that may occur while the vacuum cleaner is running. However, they cannot replace the expertise and common sense of operators as an overall framework for the prevention of accidents. Structural damage, alterations or improper repairs can modify the protective capacity of the vacuum, thereby nullifying this certification and releasing DEPURECO from any liability. Each section lists further safety measures specific to the various functions.

The manual must accompany the vacuum cleaner in case of resale.

### **ATTENZIONE!**

#### **WARNING!**

#### **Setting to work – connection to the power supply**

- Make sure there is no evident sign of damage to the vacuum cleaner before starting work.
- Before plugging the vacuum cleaner into the electrical mains, make sure the voltage rating indicated on the data plate corresponds to that of the electrical mains.
- Plug the vacuum cleaner into a socket with a correctly installed ground contact/connection.  
Make sure that the vacuum cleaner is turned off.
- The plugs and connectors of the connection cables must be protected against splashes of water.
- There are antitastic wheels
- Check that the vacuum cleaner is properly connected to the electrical mains.
- Use the vacuum cleaner only when the cables that connect to the electrical mains are in perfect condition (damaged cables could lead to electric shocks!).
- Regularly check there are no signs of damage, excessive wear, cracks or ageing on the electric cable.

#### **WARNING!**

#### **When the vacuum cleaner is operating, do not:**

- Crush, pull, damage or tread on the cable that connects to the electrical mains.
- Only disconnect the cable from the electrical mains by removing the plug (do not pull the cable).
- Only replace the electric power cable with one of the same type as the original: H07 RN - F. The same rule applies if an extension is used.
- The cable must be replaced by the manufacturer's Service Centre staff or by equivalent qualified personnel.

## **CAUTION!**

### **It is absolutely forbidden;**

- For underage and non-trained people to use this vacuum cleaner.
- To connect the vacuum cleaner to mains without suitable earthing.
- To operate the vacuum cleaner outdoors in the presence of atmospheric precipitations.
- To operate the vacuum cleaner without locking the swivelling wheel through the special brake located on it.
- To operate the vacuum cleaner on uneven ground or in non-horizontal positions.
- To operate the vacuum cleaner in corrosive environments.
- To use flexible hoses which are not wholly antistatic (superficial antistatic properties are not accepted). The use of original DEPURECO accessories is recommended. Verify electric continuity with an ohmmeter:
  1. Between the inlet and the ending part of the vacuum's accessories: The resistance measured must be inferior to 100M $\Omega$  (10<sup>8</sup>  $\Omega$ )
  2. Between the bin and the plug (ground pin) with an electric device, or between the bin and the earthing cable (supplied) with compressed air powered devices. The resistance measured must be less than 10  $\Omega$
- To operate the vacuum cleaner in working environments not classified according to the directions given on the device's plate.
- To vacuum the following materials:
  1. Flaming materials (embers, hot ashes, lit cigarettes etc...)
  2. Open flames
  3. Combustible gases
  4. Flammable, combustible or aggressive liquids (gasoline, solvents, acids, alkaline solutions etc...)
  5. Dusts/Substances and/or spontaneously combusting explosive mixtures of them (magnesium or aluminium dusts etc...)
- To tamper with or modify the return valve set up by the manufacturer
- The use of the JETCLEAN system in the presence of potentially explosive clouds in the atmosphere.
- To carry out maintenance on the vacuum cleaner in ATEX classified areas
- To carry out maintenance on the vacuum cleaner without first having switched the device off and disconnected the plug from the socket.
- To keep foreign materials such as debris, oil, tools or other objects in the bin which could disrupt the functioning and cause harm to people.
- To use flammable or toxic solvents such as gasoline, benzene, ether or alcohol for cleaning.

- To operate the vacuum cleaner without the filtering unit provided for by the manufacturer.
- To operate the vacuum cleaner without safety devices.
- To wear loose or flowing apparel such as ties, scarves, or torn clothing that could get caught on the vacuum cleaner or vacuumed by the device.
- To open the waste bin while the vacuum cleaner is working.
- To open the waste bin in an area which has been classified potentially explosive.
- To use extension leads, plug-in connection devices and adapters.
- To climb on the vacuum cleaner.
- To touch electrical wires, switches, buttons, etc. with wet hands.
- To touch some components which could reach high temperatures (such as the motor's terminal box and the motor housing in particular) while operating the vacuum cleaner.



**WARNING!**

**This vacuum cleaner could contain dust that may be hazardous to your health.**

**The emptying out and maintenance procedures, including removing the dust containers, must be carried out exclusively by specialized personnel wearing suitable safety clothing.**

**This manual must always be available for consultation on the expected operating cycle and whenever there are doubts.**

**If it is lost or damaged, a replacement copy must be requested from DEPURECO.**



## 2.3 Safety plates and symbols

Plates with safety symbols and/or messages are applied to the vacuum and its packaging.

These pages show their precise location and the nature of the hazard.



### Warning!

Ensure that all safety messages are perfectly legible.

Clean them using a cloth with water and soap. Do not use solvents, naphtha or petrol.

Request replacements for damaged plates from DEPURECO.

If a plate is located on a component that is being replaced, make sure to fit the old plate to the new component.

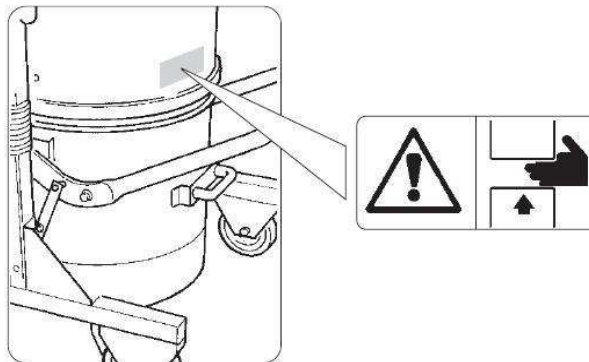

### Warning!

Crushing hazard for the upper limbs during insertion and locking of the dirt container under the vacuum cleaner.

Never place your hands between the vacuum and the dirt container while inserting and locking the later under the vacuum cleaner.

Lock the container by means of the special lever, using **BOTH HANDS**



### Warning!

Read carefully this use and maintenance manual before using the vacuum cleaner or carrying out maintenance operations on it



Read carefully the instructions on the packaging before handling the vacuum cleaner

## 2.4 Residual risks

DEPURECO recommends complying with the instructions, procedures and recommendations in this manual and with the safety standards in force. DEPURECO also recommends using suitable personal protective equipment as well as the protection devices integrated in the vacuum.

The residual risks analysed on the vacuum and/or its components could be:

### **Electrical risks during maintenance due to the requirement to work on live parts**

Pursuant to Italian Legislative Decree 81/08 – articles 80 to 87 – it is prohibited to operate on live parts, notwithstanding the exceptions set forth by said Legislative Decree.

### **Risks associated with incorrect use in presence of explosive and inflammable liquid substances**

The vacuum must not be used in environments containing liquid substances or liquids that can evaporate at room temperature, inflammable powders and gas.

### **Risks related to operation in humid environments**

Respect the limitations indicated in this manual, in section 1.8 “Authorised environmental conditions”.

### **Risk of incorrect interpretation of the safety pictograms**

With reference to risk analysis and identification, DEPURECO has installed hazard labels on the vacuum, in compliance with the standards concerning graphical symbols. The user must immediately replace any safety plate rendered illegible due to wear or damage.



#### **Warning!**

**The removal of safety plates from the vacuum and/or its components and packaging is strictly prohibited.**

**DEPURECO shall not be held liable for the vacuum's safety in the event of failure to comply with this prohibition.**

## 2.5 Applied Directives

The following directives apply to the vacuum cleaner described in this manual:

- **2006/42/EC Machinery Directive**
- **2014/30/EU Electromagnetic compatibility directive**
- **2011/65/EU - ROHS - Directive on the restriction of the use of certain hazardous substances in electrical and electronic equipment**
- **2014/35/UE – Low tension directive**
- **2014/34/UE – ATEX Directive**



Attention!

It is absolutely forbidden to remove the safety labels on the vacuum cleaner and / or on its components and on the packaging.

DEPURECO declines any responsibility for the safety of the vacuum cleaner in the event of non-compliance with this prohibition.

The regulatory references, including mandatory requirements, are managed in the Quality Management System and filed at DEPURECO

## 2.6 ATEX safety instructions



Hexagon Ex - ATEX Directive 2014/34 / EU

In this manual, the Ex-hexagon is placed next to the main safety instructions relating to the risk of explosion.



All personnel involved in installation, use and maintenance of the appliance and its components should receive technical training corresponding to the tasks to be performed, in particular for operating in areas with a potentially explosive atmosphere.

Any modification made to this equipment may invalidate its safety requirements. Always follow the manufacturer's instructions.

The equipment with II 1/3 D Ex htc IIIC T140 ° C Da / Dc marking can contain a ZONE 20 inside and can be used in ZONE 22  
 The equipment with II 1/2 D Ex h tb IIIC T140 ° C Da / Db marking can contain a ZONE 20 inside and can be used in ZONE 21 and ZONE 22  
 The zones are defined as follows.



ZONE 20: area in which an explosive atmosphere in the form of a cloud of combustible dust in the air is present permanently or for long periods or often.  
 ZONE 21: area in which occasionally during normal activities the formation of an explosive atmosphere in the form of a cloud of combustible dust in the air is likely.  
 ZONE 22: area in which during normal activities the formation of an explosive atmosphere in the form of a cloud of combustible dust is not likely and, if it occurs, it is only of short duration.  
 It is forbidden to use the appliance where there are areas classified for the presence of gas as ZONE 0, 1 or 2.

The equipment is suitable for operating only with powders without ignition sources.



Combustible dusts with the following characteristics can be treated:

Auto - flammability in MIT cloud	°C	> 215
Auto - flammability in LIT layer	°C	> 215
Minimum Ignition Energy (MIE) at all operating temperatures	mJ	≥ 3

It is forbidden to use the device with hybrid mixtures, explosives and class St2 and St3 powders, chemically unstable powders.



It is the user's responsibility to ensure that the equipment is used in accordance with its intended use, in particular that it is used in areas classified as compatible with those for which the equipment itself is declared suitable by the manufacturer.  
 The device is designed to work in standard environmental conditions:

- Temperature  $-20\text{ ° C} \leq T_{amb} \leq + 40\text{ ° C}$ .
- Atmospheric pressure + 0.8 / 1.1 bar

The treated product must have a temperature not exceeding 40 ° C.



Any electrical or mechanical components to be installed on the equipment must be certified in the category suitable for use:

- category 3D (ZONE 22)
- category 2D (ZONE 21)
- category 1D (ZONE 20)

For maintenance or cleaning operations, the user must ensure that the equipment used (aspirators, portable lamps, etc.) are of a suitable category for the environment:

- 3D category (ZONE 22)
- category 2D (ZONE 21)
- category 1D (ZONE 20)



#### INSTALLATION - START-UP

Before proceeding with installation and start-up, provide a visual check for any transport damage.

The tools used for installation must comply with the EN 1127-1 standard in relation to the area of use.

As a preliminary operation, carry out the earthing and check its correct operation. The earthing is equipped with a visual indication by means of a European standard symbol.

During start-up, carry out the following checks:

- check the correct earthing of the equipment and the condition of equipotentiality between the various parts of the equipment, in particular the moving parts;
- carry out a blank test with acoustic check (abnormal noise): in the event of problems, stop the equipment and check the assembly of the moving parts;
- the electrical wiring must be carried out by qualified personnel and according to the indications in the wiring diagram.

During the testing and delivery of the equipment, adequate training must be given to the operator who carries out installation, start-up and normal use of the equipment.



The user must ensure that the system in which the equipment will be installed has been adequately secured, from an explosion risk point of view, before starting and that the "Document on protection against explosions" as required by the ATEX Directive 1999/92 / EC (DM 81-2008).



**THE INTRODUCTION (ASPIRATION) OF IGNITION SOURCES FROM THE OUTSIDE**, including those due to self-ignition of dust or by embers, is FORBIDDEN.



In the case of aspiration of dust that may give rise to self-ignition phenomena, the collection bin must be emptied immediately after each activity.

This precaution must also be adopted in the case of suction of different types of powders whose mixture may give rise to exothermic reactions.



A periodic check of the conditions of equipotentiality must be carried out, in particular after maintenance operations, between the different metal parts of the equipment, in particular the moving parts and the baskets for sleeves.



Strictly use antistatic / dissipative components that ensure electrical continuity



The installation, assembly and disassembly operations must be carried out on switched off machines and in the absence of a potentially explosive atmosphere.



The installer must check the correspondence of the process specifications with the characteristics of the equipment shown on the plate (for example in reference to the maximum surface temperature).

In the case of material with incompatible product characteristics, the use of the equipment is prohibited.



Attached are the manuals of the ATEX components mounted on the equipment: the user must observe all safety instructions relating to the use of these components.



The cleaning of the equipment must be carried out by the user to avoid the formation of layers of combustible dust.

Do not use compressed air to clean the layers of dust, but suitable suction systems suitable for the treatment of potentially explosive dust (ATEX certified vacuum cleaners).



A specially trained operator must always be present during the operation of the equipment and must intervene immediately stopping the equipment using the emergency button in case of malfunctions, for example due to abnormal noise (breakage of components), clogging of the loading and venting, rupture of the filter bags, aspiration of bodies, presence of foreign bodies or sources of ignition.



For the installation and maintenance of electrical parts (eg. Cables, cable glands and terminals) always follow the indications of EN 60079-14.

In case of opening the junction boxes (for inspections) check the correct presence of the gaskets when they are closed again.



The plug is not of the ATEX type (or is not supplied): the user must connect the plug to a socket located in a SAFE PLACE, or must install an ATEX plug.



The flexible pipes, the suction openings and the filtering bags are of the antistatic type declared by the respective manufacturers.

It is forbidden to use components of different types.



The protection against atmospheric discharges must be present in the plant where the equipment is used.



There must be no ignition sources in the immediate vicinity of the appliance, for example:

- flames;
- embers;
- hot surfaces;
- sparks (eg caused by metal cutting);
- stray currents and cathodic protection systems;
- electrical or mechanical equipment not ATEX certified;
- electrostatic charges carried by operators or by mobile equipment;
- radio frequencies (RF) and electromagnetic waves (from 104Hz to  $3 \cdot 10^{11}$ Hz);
- electromagnetic waves (from  $3 \cdot 10^{11}$ Hz to  $3 \cdot 10^{15}$ Hz);
- ionizing radiations;
- ultrasound.

The regulatory references, including mandatory requirements, are managed in the Quality Management System and filed at DEPURECO.



### 3. HANDLING, UNPACKING AND INSTALLATION SECTION

#### 3.1 Handling



#### **Warning!**

The instructions for transporting and unpacking the vacuum correctly are shown on the packaging as well.

The following instructions also indicate the operations to be undertaken should the vacuum need to be re-packed or unpacked after subsequent transportation.

Dimensions of the packed vacuum cleaner:

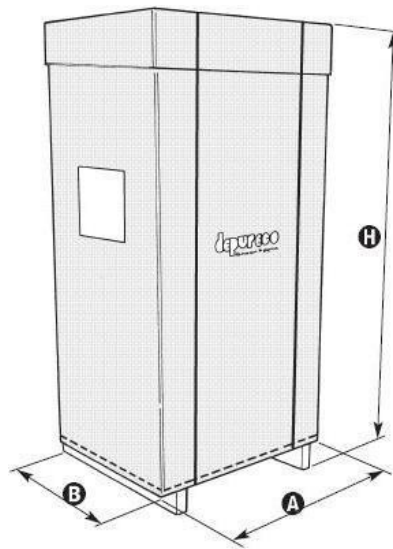

	U.M	A	B	H
All models	mm	1000	750	1900



**The vacuum cleaner must be lifted and handled exclusively using a forklift having suitable load bearing capacity.**

**When using a forklift, lift the load 200 mm off the ground and swing backwards. Always keep the height of the working environment in mind when lifting loads. Before starting any movement, ensure that the area is cleared and that there are no moving objects on the packaging. For lifting and handling, apply operating safety laws and normal instructions for fork-lift truck driving.**

### 3.2 Unpacking

- Cut and unwind the two packaging fixing belts

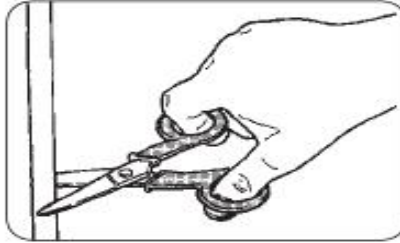

- Remove the staples that fix the carton packaging to the pallet with the aid of a screwdriver

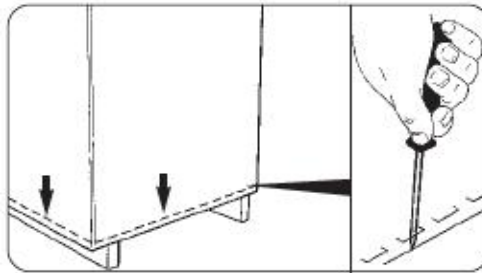

- Remove the carton completely



The cardboard packaging can be recycled. To protect the environment, make sure to dispose it off in specialised collection centres.

**Warning!**

**Keep the pallet.**

**In the event of subsequent transport, the vacuum must be secured to the pallet using the same fastening system.**

### 3.3 Installation



#### **Caution!**

**Before installing the vacuum, it is important to carry out a thorough preventive visual inspection to identify any damage which may have occurred during transport.**

In the event of one or more components being damaged, do not continue with installation, inform DEPURECO about the anomaly and agree upon action to be taken.

The vacuum cleaner is already fitted with an appropriate filter intended exclusively to vacuum dry dust or debris

- Insert the flexible hose with terminal into the special suction nozzle

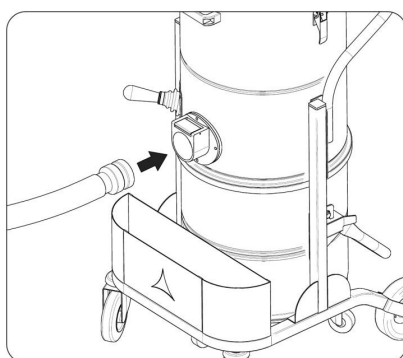

- Insert the desired accessory for the type of suction from the opposite side of the hose

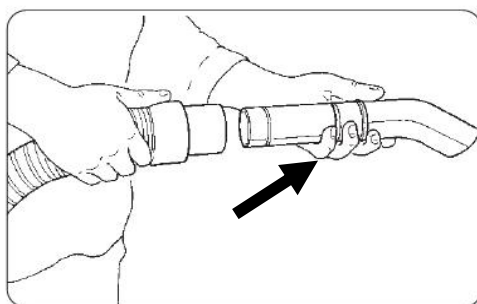

Note: the flexible tube and the relevant end-pieces and accessories are not included with the STANDARD model. Contact your dealer (or DEPURECO) for information regarding the various types of OPTIONALS that can be used on this specific model.

**The following operation must be carried out by a qualified electrician.**

Ensure that the power supply line corresponds to the voltage and frequency indicated on the identification plate and that it is efficiently earthed.

The vacuum cleaner's electrical current supply socket must be protected by a CE-marked circuit breaker. Insert the plug (standard supply) into the socket.



**Warning!**  
Do not insert the plug in the power supply socket with wet hands. Do not use extension leads.

## 4. OPERATION SECTION

### 4.1 Description of the controls



#### **Warning!**

The vacuum can be used solely by authorised personnel after having read these use and maintenance instructions. The user of the equipment and the maintenance technician, who carry out operations on the vacuum, must be adequately educated, informed and trained, in compliance with the occupational safety standards in force and, during the various operations, must wear personal protective equipment (PPE), such as safety footwear, gloves, protective goggles, mask, etc. The user must comply with the provisions in force concerning extracted materials and their disposal.

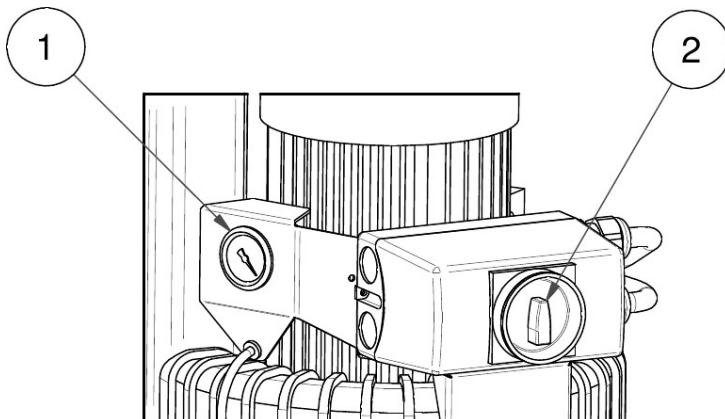

1. Vacuum gauge: signals the clogging of the filter
2. Main switch ON/OFF.

## 4.2 Operating cycle

Ensure that the power cord is intact and in perfect state.



### **Warning!**

Before inserting the plug, ensure that the voltage of the power supply line corresponds to the one indicated on the vacuum's identification plate.

- Make sure the power plug is properly inserted into the power outlet.
- Make sure that the flexible tube is regularly inserted and locked in the appropriate suction nozzle.
- Make sure that the debris collection container is regularly present and blocked under the vacuum chamber



### **Attention!**

Do not move the vacuum cleaner while it is in operation.

- Grip the end of the hose with the chosen suction accessory.
- Activate the pump and start suction.
- To turn off the aspirator, the previously activated motor must be turned off.
- Once the work is finished, disconnect the vacuum cleaner from the power outlet

To move the vacuum cleaner, use the appropriate forks on the fixed frame.



### **Warning!**

Avoid curling or kinking of the hose during suction.

## 4.3 Emptying the bin



### **Warning!**

**Wear PPE (gloves, dust mask, goggles, etc.) during this operation.**

Depending on the type and quantity of material being vacuumed, it is necessary to periodically check the bin to avoid filling it excessively.

Proceed as follows to empty the container:

- Switch the machine off by switching the main switch (1) to "0"

- block the vacuum cleaner by means of the brake located on the swivelling wheel
- unlock the container by lifting the special handle.

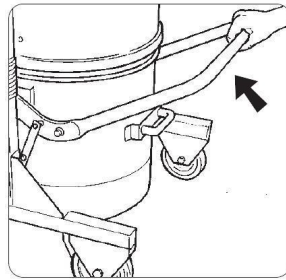

- remove the bin by using the handles

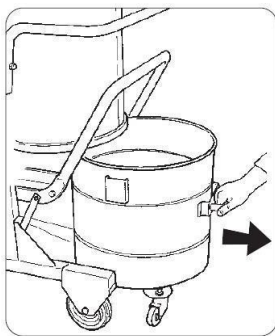

- Empty the debris into the waste disposal container

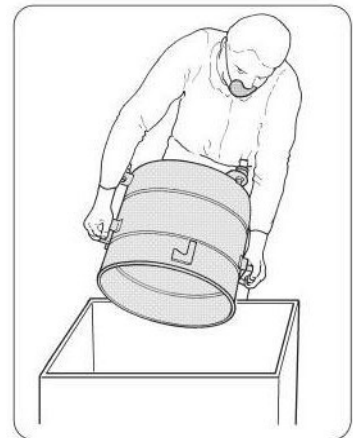

NOTE The container can also be emptied using the drain cock located on the bottom of the container itself.

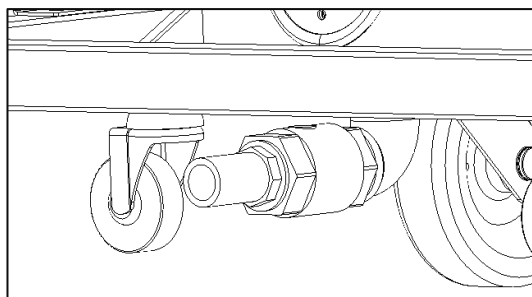



**Warning!**

**If the bin or the bag weigh more than 15 Kg, at least two people are needed to empty it.**



Disposal must be done in compliance with the existing laws for the country of use

Of the vacuum cleaner.

For Italy - Legislative decree 152/2006 and subsequent modifications.

#### 4.4 Inserting and locking the bin

To insert and lock the container, proceed as follows:

- Insert the container under the aspirator
- Fully lower the locking lever with both hands

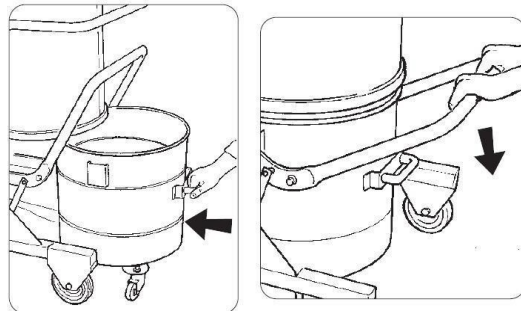

- The pins (A) must be aligned with the slots (B)

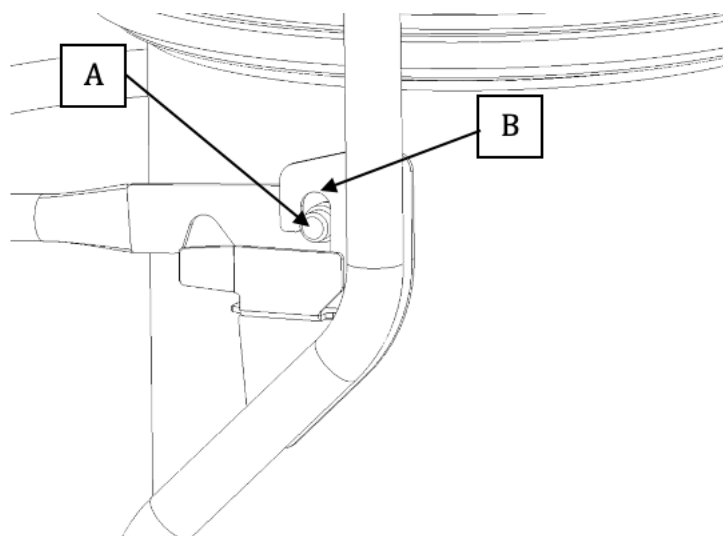

**Attention!**

Crushing hazard for the upper limbs!

Never insert your hands between the container and the aspirator during the locking operation.

**4.5 Storage – Decommissioning**

Remove the filter and clean it; empty the refuse collection container and store the vacuum in a place protected against weather agents with the temperature ranging between 5 and 45 °C and cover it with a nylon tarp to protect it against dust.

**5. MAINTENANCE SECTION****Warning!**

**Special vacuum maintenance must be carried out solely by specialised technicians authorised by the DEPURECO dealer.**

**5.1 Informative notes**

This section describes the checks and routine maintenance operations required to ensure proper vacuum operation.

Maximum reliability and minimum maintenance costs are the result of a planned maintenance and inspection schedule carefully followed throughout the entire lifespan of the vacuum.

Observe the set maintenance intervals and schedule the interventions according to specific requirements in relation with the vacuum production cycle.

Always use perfectly working tools specifically intended for the operation to be carried out; the use of inadequate or inefficient tools can cause severe damages.

Any other intervention required to remove faults or malfunctions must be expressly authorised by the manufacturer.

In these cases, always communicate the vacuum identification data - see para. 1.4 of this manual.

For significant repairs, refer to the authorised dealer, whose specialised personnel has the technological expertise and is always available for prompt interventions.

For user maintenance operations, the vacuum must be disassembled, cleaned and maintained, where possible, in such a way as to prevent hazards to the maintenance personnel and to third parties. Suitable precautionary measures include decontamination before dismantling, measures for filtered forced ventilation of the room



where the appliance is disassembled, cleaning of the maintenance area and suitable personal protection equipment.

Once every three months (or more frequently, according to the operating cycle and the conditions of use), the manufacturer or a qualified technician must check the filters, ensuring that they are not damaged; the tightness of the air system and proper operation of the control devices.

Should maintenance operations or repairs be carried out, all contaminated objects must be adequately cleaned, placed in waterproof bags and disposed of in compliance with the regulations in force.

## 5.2 General safety regulations



### **Warning!**

**All the operations described above must be carried out with the plug disconnected from the socket.**



**Before starting any maintenance or cleaning operation, wear suitable PPE (protective clothing, goggles and/or gloves, etc.) according to the work to be done.**



**Place a sign on the vacuum with the message:**

**“MACHINE UNDER MAINTENANCE  
DO NOT START”**

**Before returning to use, the whole system must be checked according starting procedures.**

**Run a few trials operating cycles after every maintenance operation to ensure proper machine operation.**

**Failure to observe these precautions can cause serious injury to personnel.**

Maintenance operations must be carried out by trained technicians specialised in the following sectors:

- Mechanical maintenance
- Electrical maintenance

It is the Safety Manager's duty to ensure the professionalism and skills of these technicians.

**Before starting any maintenance operation, the Safety Manager must:**

- Keep unauthorised personnel out of the work area.

- Ensure that the necessary tools are in good conditions and readily available to the maintenance technician.
  - Ensure the maintenance technician is equipped with the personal protection equipment required for the specific operation (gloves, goggles, shoes, mask, etc.)
  - Make sure the maintenance technician has carefully read the instructions contained in this manual and has perfectly acquired knowledge on the operation of the vacuum and its components.
- Ensure that there is enough light and, if necessary, provide 24 Volt torches.

**Before starting any maintenance operation, the Maintenance technician must:**

cut off all power supplies and set the vacuum cleaner in safety lock condition



**Warning!**

**If absolutely necessary operating with the power turned on, pursuant to Italian Legislative Decree 81/08, the maintenance technician must maintain a safe distance, prepare reachable emergency stop buttons and never place hands in the discharge container.**

At the end of the procedure and before returning to use, the maintenance technician must check that guards are functioning correctly and the protection devices are intact. Operations on the motors or on other electrical components must only be carried out by the specially trained electrical maintenance technician authorised by the Safety Manager.



**Warning!**

**After any maintenance intervention, the Health and Safety Manager is required to check the safety conditions of the vacuum cleaner and of its safety devices.**

**Before every work shift**

- Check that the power cord and the plug are not damaged: replace them immediately if there are any signs of wear, using a cord of the same type (information c/o DEPURECO). This operation is the sole responsibility of an electrician.
- Check the integrity of the safety symbols (pictograms) applied to the vacuum cleaner.
- Verify the efficiency of the filters by checking the vacuum gauge.
- Check the integrity of the hose and of the accessories to be used.



**Warning! The flexible hose, if perforated, reduces the suction power and releases dust into the surrounding environment.**

**The flexible hose, if perforated, reduces the suction power and releases dust into the surrounding environment.**

### 5.3 Replacing the filter



**Warning!**  
**Wear appropriate PPE (dust mask, latex gloves, goggles, etc.).**

To replace the filter, proceed as follows:

- Switch off the vacuum cleaner
- Disconnect the vacuum cleaner from the power supply
- Remove the container
- With the help of suitable equipment, remove the inerting filter kit to replace it

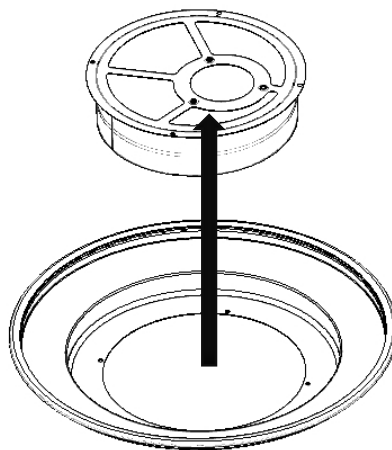
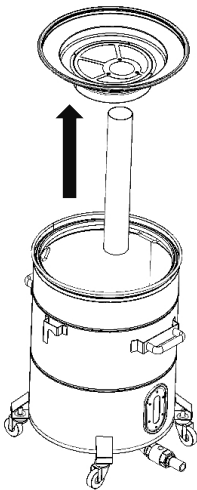

- Remove the bag filter from the basket to clean / wash it (or replace it if necessary)

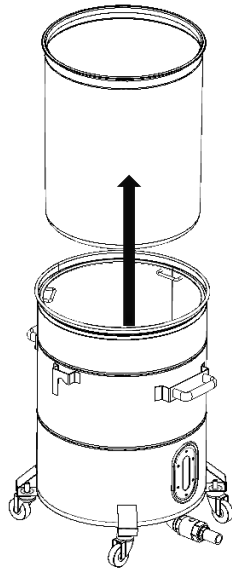

- Unlock the two closing hooks of the head base on the filter chamber (C) from both sides

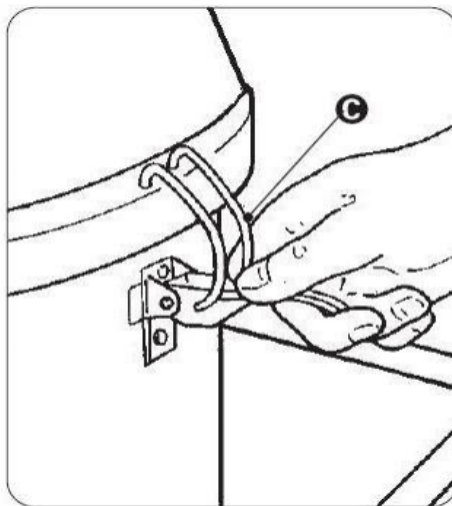

- Remove the head with its base.

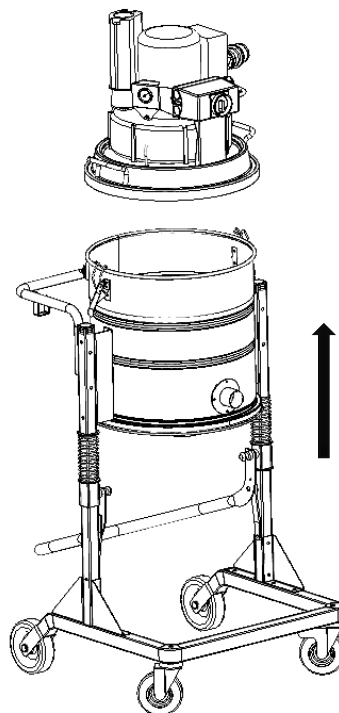

- With the aid of suitable equipment, extract the conical cartridge and replace it

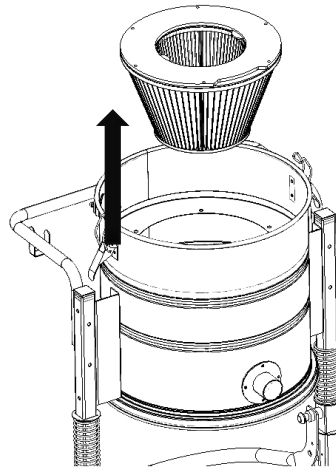

**Remove the filter, place it inside a plastic bag, close it and dispose of it according to the laws in force for the type of material sucked up**

**To reassemble the filters**, proceed as follows:

- Insert and fix the new conical cartridge in its special support inside the aspirator chamber, paying attention to its correct positioning and alignment
- Place the head with its base on the chamber and lock it to the latter using the two hooks (C)
- Insert the bag filter inside the basket
- Position and fix the inerting filter kit in the conical support ring
- Insert the conical ring into the container
- Connect the power supply Turn on the vacuum cleaner and immediately evaluate its regular operation.

**USE ONLY ORIGINAL DEPURECO FILTERS**

## 5.4 Troubleshooting

ANOMALY	POSSIBLE CAUSE	RECOMMENDED SOLUTION
The vacuum cleaner will not start	No power supply	<p>Verify the presence of voltage in the socket</p> <p>Verify the integrity of the plug and the power cable</p> <p>Contact DEPURECO's technical assistance service</p>
Dust comes out of the vacuum cleaner	Perforated filter	Replace the filter
	Filter not suitable for the vacuumed material	Install a filter which is suitable for the vacuumed material

## 5.5 Scrapping

This product falls within the scope of the Directive 2012/19 / EU concerning the management of waste electrical and electronic equipment (WEEE). The appliance must not be disposed of with household waste as it is made up of different materials that can be recycled at appropriate facilities. Inquire through the municipal authority regarding the location of ecological platforms suitable for receiving the product for disposal and its subsequent proper recycling. Furthermore, we remind you that in the event of the purchase of equivalent equipment, the distributor is required to collect the product to be disposed of free of charge. The product is not potentially dangerous to human health and the environment, as it does not contain harmful substances such as Directive 011/65 / EU (RoHS), but if abandoned in the environment it has a negative impact on the ecosystem. Read the instructions carefully before using the appliance for the first time. It is recommended not to use the product for any purpose other than that for which it was intended, as there is a danger of electric shock if used improperly.



Il simbolo del bidone barrato presente sull'etichetta posta sull'apparecchio, indica la rispondenza di tale prodotto alla normativa relativa ai rifiuti di apparecchiature elettriche ed elettroniche. L'abbandono nell'ambiente dell'apparecchiatura o lo smaltimento abusivo della stessa sono puniti dalla legge.

**If in doubt, do not interpret! Call your dealer immediately!**

REGISTRATION IN THE AEE REGISTER N. IT18090000010711



MAINTENANCE REGISTER:

INTERVENTION 1:

DATE:

TECHNICAL ASSISTANCE:

TYPE OF INTERVENTION:

---

INTERVENTION 2:

DATE:

TECHNICAL ASSISTANCE:

TYPE OF INTERVENTION:

---

**INTERVENTION 3:**

**DATE:**

TECHNICAL ASSISTANCE:

TYPE OF INTERVENTION:

---

**INTERVENTION 4:**

**DATE:**

TECHNICAL ASSISTANCE:

TYPE OF INTERVENTION:



