

# USER MANUAL AND MAINTENANCE



## SERIES **MINIAIR - XM 20 AIR JC**

### TRANSLATION OF ORIGINAL INSTRUCTIONS

---

#### Depureco Industrial Vacuums Srl

Company subject to management and coordination COFISE spa

Via Venezia, 32 - 10088 Volpiano (TO)

Tel. +39 011 98.59.117

Fax. +39 011 98.59.326

[www.depureco.com](http://www.depureco.com)

[depureco@depureco.com](mailto:depureco@depureco.com)

[depureco@documentipec.com](mailto:depureco@documentipec.com)

C.F. and P.I. 02258610357 - Capital stock: € 25,000 i.v.

Turin Business Register - R.E.A. TO-1149668

Registration **WEEE** No. IT18090000010711





---

## INDEX

<b>1. INFORMATION SECTION</b>	<b>7</b>
1.1. Preface	7
1.2. Identification of major parts	9
1.3. Optional parts	10
1.4. Manufacturer identification data	10
1.5. Name plate	10
1.6. ATEX Marking	10
1.7. Intended uses	10
1.8. Allowable environmental conditions	11
1.9. Noise level	11
1.10. Technical Data	12
1.11. Warranty	13
<b>2. SAFETY SECTION</b>	<b>15</b>
2.1. Safety information	15
2.2. Safety prescriptions	15
2.3. ATEX Safety Instructions	18
2.4. Safety plates and symbols	20
2.5. Residual risks	22
2.6. Directives applied	22
<b>3. HANDLING, UNPACKING AND INSTALLATION SECTION</b>	<b>23</b>
3.1. Handling	23
3.2. Unpacking	24
3.3. Installation	25
<b>4. OPERATION SECTION</b>	<b>27</b>
4.1. Command description	27
4.2. Duty cycle	28
4.3. Air speed control	29
4.4. Filter cleaning cycle	29
4.5. Emptying the container	31
4.6. Inserting and locking the container	33
4.7. Storage - decommissioning	34



---

<b>5. MAINTENANCE SECTION</b>	<b>35</b>
5.1. Informational Notes	35
5.2. General safety standards	35
5.3. Primary filter replacement	37
5.4. HEPA filter replacement	40
5.5. If something doesn't work	42
5.6. Scrapping	42



## DECLARATION OF CONFORMITY FOR NON ATEX VERSIONS



### DECLARATION OF COMPLIANCE

The manufacturer:

**DEPURECO INDUSTRIAL VACUUMS S.r.l.** – Via Venezia, 32 – 10088 Volpiano (TO) – ITALY |

**Phone.** +39 011 98 59 117 – **Fax** + 39 011 98 59 326 – **Tax code.** | **VAT REG. NO.**

02258610357

**e-mail:** [depureco@depureco.com](mailto:depureco@depureco.com) – [www.depureco.com](http://www.depureco.com)

**hereby declares**

under their sole responsibility that the vacuum cleaner model described in this manual



To which this declaration refers, complies with the essential safety requirements provided by the **Machinery Directive 2006/42/EC**, the **Directive 2014/30/EU** regarding Electromagnetic Compatibility and the **Directive 2011/65/EU - ROHS** - regarding restriction of the use of certain hazardous substances in electrical and electronic appliances.

The conformity has been verified in accordance with the requirements mentioned by the Standards:

**EN 60335-1**

**EN IEC 61000-3-2:2019**

**EN IEC 63000:2018**

**EN 60335-2-69**

**EN 55014-2:2015**

The Harmonised Standards applied for the design, manufacture and testing of the vacuum cleaner are listed in a technical file stored at the technical department of DEPURECO S.r.l. premises.

**The production control was carried out by Notified Body No. 0474 RINA Services S.p.a.**

This declaration shall become invalid if modifications on the vacuum cleaner are carried out without approval from the manufacturer.

First issue: 15 June 2019

Revision 01: 16 October 2023

Revision 02: 26 April 2024

  
The Legal Representative  
Marco Devincentis

**Depureco Industrial Vacuums Srl**  
Società soggetta a direzione e coordinamento COPISE spa

PERFORMANCE ON VACUUM SINCE 1972

Via Venezia, 32 - 10088 Volpiano (TO)  
**Tel.** +39 011 98.59.117  
**Fax** +39 011 98.59.326

[www.depureco.com](http://www.depureco.com)  
[depureco@depureco.com](mailto:depureco@depureco.com)  
[depureco@documentipec.com](mailto:depureco@documentipec.com)

**C.F. e P.I.** 02258610357  
Registro Imprese di Torino - **R.E.A.** TO-1149668  
**Capitale Sociale:** € 25.000 i.v.



## DECLARATION OF CONFORMITY FOR ATEX VERSIONS



### DECLARATION OF COMPLIANCE

The manufacturer:

**DEPURECO INDUSTRIAL VACUUMS S.r.l.** – Via Venezia, 32 – 10088 Volpiano (TO) – ITALY |  
Phone. +39 011 98 59 117 – Fax + 39 011 98 59 326 – Tax code. | VAT REG. NO.  
02258610357

e-mail: [depureco@depureco.com](mailto:depureco@depureco.com) – [www.depureco.com](http://www.depureco.com)

hereby declares

under their sole responsibility that the vacuum cleaner model described in this manual



To which this declaration refers, complies with the essential safety requirements provided by the Machinery Directive 2006/42/EC, the Directive 2014/30/EU regarding Electromagnetic Compatibility, the Directive 2011/65/EU - ROHS - regarding restriction of the use of certain hazardous substances in electrical and electronic appliances and by the ATEX Directive 2014/34/EU with the following details.

The conformity has been verified in accordance with the requirements mentioned by the Standards:

UNI EN 1127-1:2019      UNI EN ISO 80079-36:2016      EN 60079-0:2018      EN60079-31:2014

Marking:   II 3 G/D Ex htc IIIB T100°C Gc/Dc

The Harmonised Standards applied for the design, manufacture and testing of the vacuum cleaner are listed in a technical file stored at the DEPURECO S.r.l. premises.

This declaration shall become invalid if modifications on the vacuum cleaner are carried out without approval from the manufacturer.

First issue: 15 June 2019  
Revision 01: 16 October 2023.

  
The Legal Representative  
Marco Devinentis

**Depureco Industrial Vacuums Srl**  
Società soggetta a direzione e coordinamento COFISE spa

PERFORMANCE ON VACUUM SINCE 1972

Via Venezia, 32 - 10088 Volpiano (TO)  
Tel. +39 011 98.59.117  
Fax +39 011 98.59.326

[www.depureco.com](http://www.depureco.com)  
[depureco@depureco.com](mailto:depureco@depureco.com)  
[depureco@documentipeccom](mailto:depureco@documentipeccom)

C.F. e P.I. 02258610357  
Registro Imprese di Torino - R.E.A. TO-1149668  
Capitale Sociale: € 25.000 i.v.



## 1. INFORMATION SECTION

IMPORTANT - The term and logo DEPURECO in this document refer to and are the property of DEPURECO INDUSTRIAL VACUUMS S.r.l.

This document is the exclusive property of DEPURECO S.r.l. Therefore, its reproduction by any means (graphic, computer, etc.), partial or total, is prohibited without the authorization of the Company Management.

### 1.1. PREFACE

Dear Customer

Thank you for choosing DEPURECO, and congratulations on selecting a DEPURECO vacuum cleaner from the MINIAIR series

We have prepared this manual to enable you to fully appreciate the quality of this machine.

We recommend reading it thoroughly before using the product for the first time.

It contains important information, tips and warnings for the use and maintenance of the vacuum cleaner that will help you take full advantage of the technical features of your machine.

**It is recommended to read carefully the messages, warnings and directions, preceded by the symbols:**



For the safety of people.



For the integrity of the aspirator.



For the preservation of the environment.

This manual describes the following models:

- MINIAIR 2V
- MINIAIR 2V Z2-Z22

**Machines are classified according to their degree of dust filtration efficiency:**

- L (light risk): in vacuum cleaners with a class L filter, the maximum degree of dust penetration is less than 1 percent (Degree of penetration < 1 %);
- M (medium risk): in vacuum cleaners with M filter, the maximum degree of dust particle penetration is less than 0.1 percent (Degree of penetration < 0.1 %);
- H (high hazard): in vacuum cleaners with filter H, the maximum degree of dust particle penetration is less than 0.005% (Degree of penetration < 0.005 %); This vacuum cleaner is designed to perform vacuuming, cleaning and collection operations of solid materials (dust and processing residues).

This specific model has undergone strict testing to ensure maximum reliability; its smooth operation and longevity will depend on good maintenance and careful use.



---

This manual is an integral part of the vacuum cleaner and must accompany it, until it is scrapped. In case of loss or damage, a replacement copy should be requested from DEPURECO INDUSTRIAL VACUUMS S.r.l. (hereafter referred to simply as DEPURECO).

The technical information contained in this manual is the property of DEPURECO and should be considered confidential in nature.

Reproduction, even in part, of the graphic design, text and illustrations is prohibited by law.

Some details depicted in the illustrations in this manual may differ from those in your vacuum cleaner, as some components may have been removed in order to ensure maximum clarity of the illustrations.

The topics covered in this manual, are those expressly required by the Machinery Directive 2006/42/EC and the technical data given are derived from the technical file stored at DEPURECO.

In compliance with Regulation 1907/2006/EC (REACH), DEPURECO declares that its products do not contain any of the substances, so-called substances of very high concern - SVHC i.e. Substances of Very High Concern - listed in the Candidate List.

This manual can be accessed via the QR code affixed to the vacuum cleaner or via the website [www.depureco.com](http://www.depureco.com). Alternatively, contact the manufacturer Depureco. The manual should be made available to all personnel responsible for operating and maintaining the vacuum cleaner. For any dispute, the Court of Turin (Italy) shall have jurisdiction.

**The QR code with the manual must accompany the vacuum cleaner in case of resale!**



## 1.2. IDENTIFICATION OF MAJOR PARTS

MINIAIR 2V  
MINIAIR 2V Z2-22 

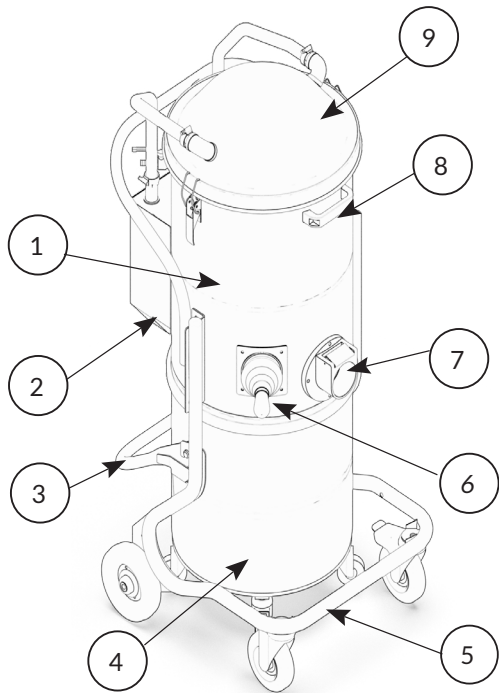

XM 20 AIR JC

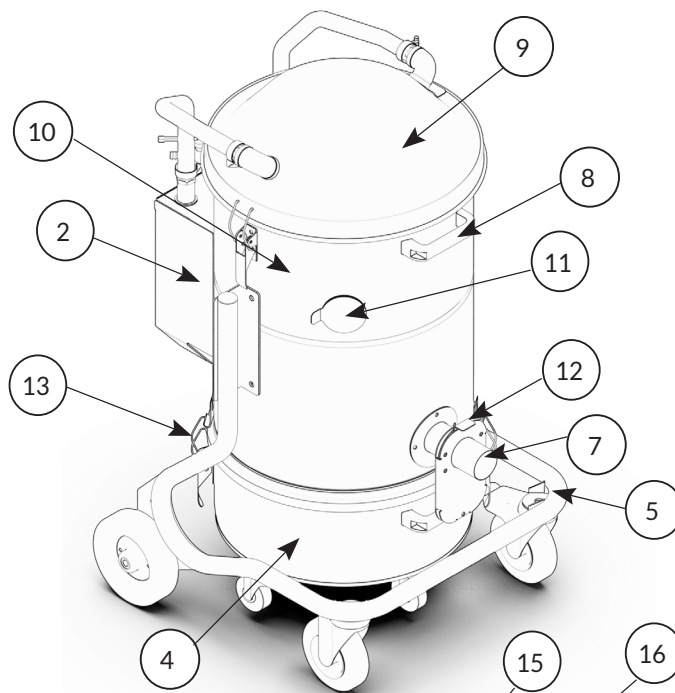

1. Filter chamber
2. Ejector box
3. Lever for unhooking, hooking and transporting the container
4. Dust/debris collection container
5. Frame
6. Lever for manual filter shaking
7. Suction nozzle
8. Handle for handling the vacuum cleaner
9. Head with pneumatic connections
10. Filter chamber with an additional HEPA filter inside
11. JetClean® cleaning plate
12. JetClean® Cleaning Damper
13. Container closing hooks
14. Adjustable vacuum generator
15. Ball valve

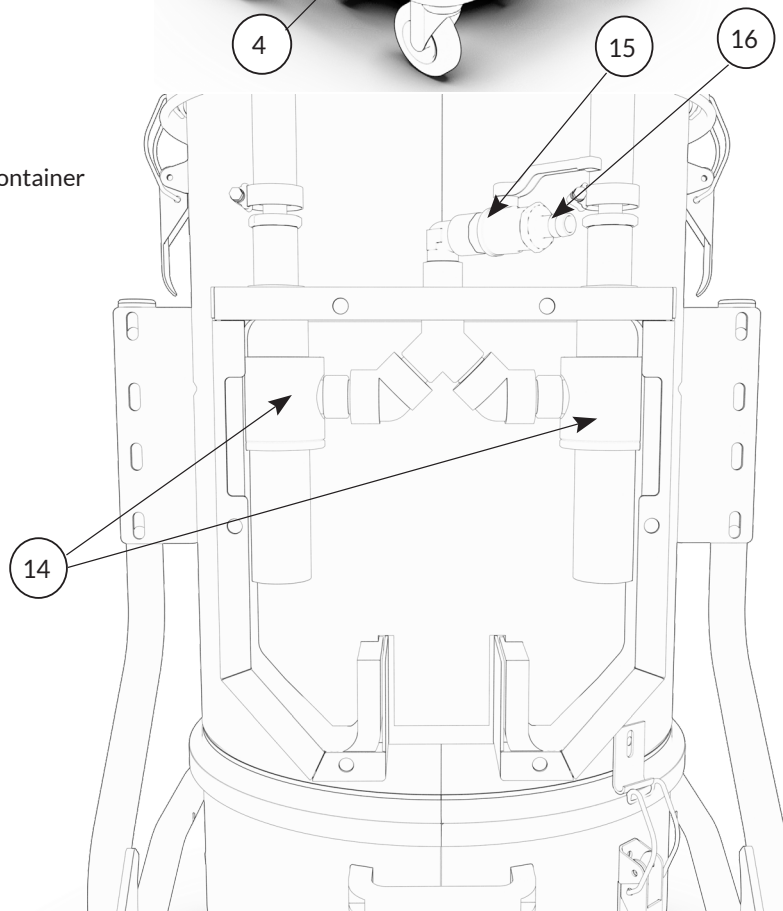



### 1.3. OPTIONAL PARTS

Depending on the vacuum cleaner's application, a wide range of other optional accessories is available from DEPURECO.

### 1.4. MANUFACTURER IDENTIFICATION DATA

Depureco Industrial Vacuums S.r.l.  
Via Venezia 32, 10088, Volpiano (TO), Italy  
tel: +39 011 98 59 117 fax: +39 011 98 59 326 P.I. 02258610357  
e-mail: depureco@depureco.com  
website: www.depureco.com

### 1.5. NAME PLATE

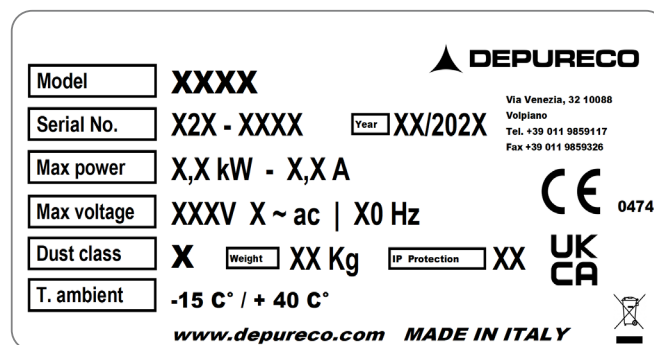

### 1.6. ATEX MARKING

MINIAIR 2V Z2-Z22

CE  II 3 G/D Ex htc IIIB 100°C Gc/Dc

### 1.7. INTENDED USES

MINIAIR 2V - XM 20 AIR JC

These vacuum cleaners are manufactured according to the Machinery Directive 2006/42/EC, are designed to be used by a single operator and are intended for:

- to industrial use, such as in manufacturing plants or warehouses;
- To dry/wet cleaning of floors or walls;
- To the suction of wet or damp substances;
- To the extraction of dry, non-combustible dust.

### **WARNING**

Where there is the presence of combustible dust and/or flammable gases in the workplace, it is the responsibility of the Employer to make the classification of the area and choose a Category machine (as defined in Directive 2014/34/EU).

Any other use is considered **NON-COMPLIANT** with the intended use.



## MINIAIR 2V Z2 - Z22

These vacuum cleaners are built according to Directive 2014/34/EU, are designed to be used by a single operator, and are intended for:

- to industrial use, such as in manufacturing plants or warehouses;
- To indoor and indoor use;
- to 'aspiration of combustible dust and/or dry particles in atmospheres classified as **Zone 2 - Zone 22**
- aspirated particles must have the following limitations:  
**Minimum ignition energy (MIE) of the powder > 3 mJ.**

### **WARNING**

It is the responsibility of the Employer to make the zone classification and choose a Category machine (as defined in Directive 2014/34/EU)

Any other use is considered **NON-COMPLIANT** with the intended use.

## 1.8. ALLOWABLE ENVIRONMENTAL CONDITIONS

To ensure proper operation of the vacuum cleaner, it must be located away from the weather (rain, hail, snow, fog, suspended dust, etc.), with an ambient temperature between -15 °C and 40 °C and humidity not exceeding 70%.

The work environment should be clean and adequately bright.

## 1.9. NOISE LEVEL

Phonometric tests carried out on this specific vacuum cleaner model show a sound pressure level of:

Machine	Noise level
MINIAIR 2V	78 dB(A)
MINIAIR 2V Z2-Z22	73 dB(A)
XM 20 AIR JC	78 dB(A)

### **WARNING**

- For sound pressure levels above 85 dB(A), workers must be protected by appropriate personal protective equipment (PPE), such as approved individual hearing protectors.
- For such conditions, it is necessary to provide workers with training and information on the risks of noise exposure.



## 1.10. TECHNICAL DATA

	Unit of measurement	MINIAIR 2V	MINIAIR 2V Z2-22	XM20 AIR JC
<b>Weight</b>	[kg]	40	42	30
<b>Dimensions</b>	[mm]	550 x 620	550 x 620	540 x 570
<b>Height</b>	[mm]	1150	1150	890
<b>Required air</b>	[L/min]	2,500	2,500	2,500
<b>Required pressure</b>	[Bar]	6-8	6-8	6-8
<b>Suction mouth diameter</b>	[Ø mm]	70	70	50
<b>Motors type</b>		2 Venturi ejectors	2 Venturi ejectors	2 Venturi ejectors
<b>Max vacuum / Continuous vacuum</b>	[m Bar]	500 / -	500 / -	500 / -
<b>Max air flow rate</b>	[m <sup>3</sup> /h]	250	300	250
<b>Primary filter</b>		Stellar	Stellar	Conical Cartridge
<b>Primary filter surface</b>	[cm <sup>2</sup> ]	15000	15000	35000
<b>Media</b>		Polyester	Antistatic polyester	Polyester antistatic
<b>Absolute filter</b>		HEPA H14 *	HEPA H14 *	HEPA H14
<b>Absolute filter surface</b>	[cm <sup>2</sup> ]	22000	22000	22000
<b>Noisiness</b>	[dB(A)]	78	73	78
<b>Container capacity</b>	[L]	45	45	20

\* = optional filter

The vacuum cleaner can be equipped with the following filters, distinguished between the supplied and optional filters:

	STELLAR M	STELLAR M ANTISTATIC	STELLAR M TEFLONATED	STELLAR NOMEX	STELLAR M PTFE	STELLARE M ANTISTATIC PTFE	CARTRIDGE CONICA ANTISTATIC	CARTRIDGE HEPA H14
<b>MINIAIR 2V</b>	●	-	○	○	○	-	-	○
<b>MINIAIR 2V Z2-22</b>	-	●	-	-	-	○	-	○
<b>XM20 AIR JC</b>	-	-	-	-	-	-	●	●

● = filter supplied with the vacuum cleaner

○ = optional filter



## 1.11. WARRANTY

DEPURECO guarantees this model of vacuum cleaner for a period of 12 months from the date of purchase, indicated on the fiscal document at the time of delivery of the product. The warranty shall be void if the vacuum cleaner has been repaired by unauthorized third parties or if equipment, accessories or components not supplied or authorized by DEPURECO or for which the serial number is found to have been removed (during the warranty period) are used. DEPURECO agrees to repair or replace free of charge those parts or components that within the warranty period are proven to be defective from manufacture.

Repairs are carried out exclusively at our premises or at the Service Center indicated by us and must be received carriage paid (freight charges to be paid by the user, unless otherwise agreed).

The warranty does not cover the cleaning of working organs.

The purchase tax document must be shown to the authorized technical personnel performing the repair or must accompany the vacuum cleaner in shipment. Defects not clearly attributed to material or manufacture will be investigated exclusively at our office or at our designated Technical Service Center. Should the claim prove to be unjustified, all costs of repair and/or replacement of parts, will be charged to the purchaser.

Excluded from the warranty are: accidental damage due to transportation, carelessness or inadequate handling, improper use, not in accordance with the warnings in this booklet, or arising from phenomena not dependent on normal use/operation of the vacuum cleaner.

DEPURECO is not liable for any personal injury or property damage resulting from improper or incorrect use of the vacuum cleaner.

For any dispute, the Court of Turin (Italy) shall have jurisdiction.





## 2. SAFETY SECTION

### 2.1. SAFETY INFORMATION

Pursuant to Legislative Decree 81/08 and subsequent additions and amendments, the Head of the Safety has an obligation to train, inform and educate workers on the hazards involved in vacuum cleaner use so that they are able to protect their own and others' safety.

Failure to observe basic safety regulations or precautions, could result in an accident during the use, maintenance and repair of the vacuum cleaner. An accident can often be avoided by recognizing potential dangerous situations before they occur. Proper training is the basic prerequisite for this.

DEPURECO cannot under any circumstances be held responsible for accidents or damage resulting from the use of the vacuum cleaner by personnel who have not been adequately instructed or who have misused it, as well as from failure to comply, even partially, with the accident prevention regulations and intervention procedures contained in this manual.

Safety precautions and warnings are given in this manual and on the product itself. Failure to pay attention to these warning messages can result in accidents with serious consequences for oneself and other people.

DEPURECO carefully designs and manufactures the equipment and its accessories, identifying and compensating for all possible risks associated with its use. In the event that tools, procedures, working methods or techniques are used, which are not explicitly provided for by DEPURECO, it will be necessary to ascertain in advance, that there are no dangers to oneself and others, however, the responsibility of DEPURECO remains excluded

#### **WARNING**

Use only original Depureco spare parts. We disclaim any responsibility for the use of non-original spare parts.

### 2.2. SAFETY PRESCRIPTIONS

#### **WARNING**

The directions below play an important role in completely preserving you from all the hazards you may encounter when operating the vacuum cleaner.

However, they will not be able to be separated from the competence and common sense of those who work, as an overall framework for careful accident prevention.

Additional safety requirements specific to different operations are listed in each section.

Prior to use, operators should receive the necessary training in the use of the machine and information on the substances for which it is to be used, including safe methods for removal and disposal of collected material.

#### ***During operation, avoid:***

- Step on, crush, pull or damage the power connection cable.
- Disconnect the cable from the mains only by pulling the plug (do not pull the cable itself).
- When replacing the power supply cable, replace it with one of the same type as the original one installed.

#### ***It is absolutely forbidden:***

- Use of this vacuum cleaner by persons who are not adults and properly trained.



- Outdoor use in the presence of atmospheric precipitation.
- The use and storage of the vacuum cleaner outdoors in humid conditions.
- The use of the vacuum cleaner in the absence of the appropriate lock placed on the rotating wheel during vacuuming operations.
- The use of the vacuum cleaner placed on unlevel and non-horizontal surfaces.
- Use in corrosive environments.
- Roll or bend the hose during suction.
- For ATEX versions and models, the use of hoses that are not antistatic in the mass (only surface antistaticity is not allowed).
- The use of original DEPURECO accessories is recommended. Check with an ohmmeter for electrical continuity:
  - between nozzle and end of suction accessories: the resistance detected must be less than  $100M\Omega$  (for ATEX versions and models);
  - between the housing and the ground wire (supplied) for compressed-air models: the measured resistance must be: - less than  $10\Omega$  (for models and versions designed for compressed-air power supply).
- Use of the machine in unclassified working environments according to the information on the machine's nameplate.
- Vacuum the following materials:
  - burning materials (embers, hot ashes, lit cigarettes, etc.);
  - open flames;
  - combustible gases;
  - Flammable, combustible, aggressive liquids (gasoline, solvents, acids, alkaline solutions, etc.);
  - Explosive and spontaneously igniting dusts/substances and/or mixtures thereof (magnesium powders, etc.).
- Prolonged contact with solvents and inhalation of their vapors.
- Use near open flames or heat sources; then ensure adequate ventilation.
- The use of the exhaust fan in rooms where the suitable air exchange rate is not guaranteed, in the case where exhaust air is recirculated in the said room. To meet the required limit values, the recirculation volume flow rate must not exceed 50% of the volume of fresh air.
- Tamper with or change the limiting valve set by the manufacturer (in models where present).
- Do not use the JetClean cleaning system in the presence of potentially explosive clouds in the atmosphere (for models and versions where this cleaning system is provided).
- Perform maintenance on the industrial vacuum cleaner in ATEX classified areas (for ATEX models and versions).
- Keep foreign materials such as debris, oil, tools and other objects inside the container that could damage operation and cause personal injury.
- The use of flammable or toxic solvents such as gasoline, benzene, ether and alcohol for cleaning.
- Use without the filter unit provided by the manufacturer.
- The use of the industrial vacuum cleaner in the absence of safety devices or with such devices inefficient
- The use of the industrial vacuum cleaner with guards and guards not in place.
- Insert hands inside the container positioning guides and between the container and the vacuum cleaner during the operation of Inserting and locking the debris container under the vacuum cleaner itself: movement of the lifting handle can cause fingers to be crushed. Therefore wear gloves when removing the suction head, filter unit or collection container.
- Open the container with the vacuum cleaner running.
- Open the container in the area classified as potentially explosive.
- Add extension lines, plug-in connection devices and adapters.
- Get on the vacuum cleaner.
- Move the vacuum cleaner while it is running.
- Wear loose or dangling garments such as ties, scarves, torn clothing that can snag or be sucked up by the vacuum cleaner.
- Touching, while using the industrial vacuum cleaner, some components (motor terminal board, motor body in particular) that may reach high temperatures.

 **WARNING**



---

This vacuum cleaner may contain dust that is harmful to health.  
Emptying and maintenance procedures, including the disposal of dust collection containers, should be carried out only by trained personnel wearing appropriate protective equipment.  
This manual should always be available for reference on the planned operating cycle and whenever there is any doubt.  
If it is lost or damaged, a replacement copy should be requested from DEPURECO.



## 2.3. ATEX SAFETY INSTRUCTIONS



- Hexagon Ex - ATEX Directive 2014/34/EU. In this manual, the Ex hexagon is placed alongside the main safety instructions on explosion risk.
- All personnel involved in installation, operation and maintenance of the equipment and its components should receive technical training corresponding to the tasks to be performed, particularly for working in areas with a potentially explosive atmosphere. Any changes made to this equipment may invalidate its safety requirements. Always follow the manufacturer's instructions.
- ZONE 22: An area where during normal activities an explosive atmosphere in the form of a combustible dust cloud is not likely to form and, if it does occur, is only of short duration. It is prohibited to use the apparatus where there are areas classified for the presence of gas as ZONE 0, 1 or 2
- Combustible powders with the following characteristics can be processed:

Self flammability in MIT cloud	°C	>215
Self-flammability in LIT layer	°C	>215
Minimum Trigger Energy (MIE) at all operating temperatures	°C	≥3

- It turns out that it is prohibited to use the device with hybrid mixtures, explosives and class St2 and St3 chemically unstable dusts.
- Depureco ATEX vacuum cleaners are certified for use in ATEX Zone 22, where, during normal activities, an explosive atmosphere is not likely to form and, if it does occur, is only of short duration. It is prohibited to use the equipment where areas classified as ZONE 0, 1 or 2 are present.
- It is the responsibility of the user to ensure that the equipment is used in a manner consistent with its intended use, particularly that it is used in ZONES classified as compatible with those for which the equipment is declared suitable by the manufacturer.
- The 'device is designed to work under standard environmental conditions:
  - Temperature  $-15^{\circ}\text{C} \leq T_{\text{amb}} \leq +40^{\circ}\text{C}$ .
  - Atmospheric pressure  $+0.8/1.1$  bar.The treated product should have a temperature not exceeding  $40^{\circ}\text{C}$ .
- Any electrical or mechanical components to be installed on the equipment must be certified of a category suitable for use:
  - Category 3G/D (Zone 2 - Zone 22).
- For maintenance or cleaning operations, the user should ensure that the equipment used (vacuum cleaners, portable lamps, etc.) is of a category suitable for the environment:
  - Category 3G/D (ZONE 2 - ZONE 22).
- A periodic check of the equipotentiality condition, especially after maintenance operations, between the different metal parts of the equipment, especially the moving parts and filter cages, must be carried out.
- Strictly use antistatic/dissipative components that ensure electrical continuity.
- Before installation and start-up, provide visual inspection for possible transport damage. Instruments used for installation must comply with EN 1127-1 in relation to the area of use. As a preliminary operation carry out grounding and verification of its proper operation. Grounding is provided with visual indication by symbol in European Standard. In Start-up phases carry out the following checks:
  - Verify the proper grounding of the equipment and the condition of equipotentiality between the various parts of the equipment, especially the moving parts;
  - Carry out blank test with acoustic verification (abnormal noise): in case of problems stop the equipment and check the assembly of moving parts;
- Adequate training of the operator who performs installation, start-up and normal operation maneuvers of the equipment must be done during the testing and delivery of the equipment.
- The user must ensure that the plant within which the equipment will be installed has been adequately secured, from an explosion risk point of view, before it is started up, and also that the "Explosion Protection Document" has been prepared as required by the ATEX Directive 2014/34/EU.
- THE INTRODUCTION (ASPIRATION) OF SOURCES OF INJECTION FROM OUTSIDE, including those due



to self-ignition of dust or by embers combustion, IS PROHIBITED.

- In the case of extraction of dusts that may give rise to self-ignition phenomena, the collection bin must be emptied immediately after each activity. This precaution should also be taken in the case of aspiration of dust of different types whose mixture may give rise to exothermic reactions.
- A periodic check of the equipotentiality condition, especially after maintenance operations, between the different metal parts of the equipment, especially the moving parts and the handle baskets, must be carried out.
- Installation, assembly and disassembly operations must be carried out on machinery that is switched off and in the absence of a potentially explosive atmosphere.
- The installer must check that the process specifications correspond to the equipment characteristics on the nameplate (e.g., with reference to the maximum surface temperature). In the case of material with incompatible product characteristics, use of the equipment is prohibited.
- Manuals for the ATEX components mounted on the equipment are provided in the appendix: the user must observe all safety instructions regarding the use of these components.
- Cleaning of equipment to prevent the formation of combustible dust layers must be carried out by the user. Do not use compressed air for cleaning from dust layers, but appropriate vacuum systems suitable for handling potentially explosive dust (ATEX-certified vacuum cleaners).
- A specially trained operator must be present at all times during the operation of the equipment and must take immediate action by stopping the equipment using the emergency button in case of malfunctions, e.g., abnormal noise (rupture of components), clogging of the inlet and vent piping, rupture of the filter sleeves, suction of foreign bodies presence or sources of ignition.
- Hoses, suction nozzles and filter sleeves are of the antistatic type declared by their respective manufacturers. It is forbidden to use other types of components.
- Protection against atmospheric discharge must be present in the establishment where the equipment is used.
- No ignition sources should be present in the immediate vicinity of the device, for example:
  - flames;
  - embers;
  - hot surfaces;
  - sparks (e.g., caused by metal cutting);
  - Stray currents and cathodic protection systems;
  - Electrical or mechanical equipment that is not ATEX certified;
  - Electrostatic charges carried by operators or mobile equipment;
  - Radio frequency (RF) and electromagnetic waves (from  $10^4\text{Hz}$  at  $3 \times 10^{11}\text{Hz}$ );
  - electromagnetic waves (from  $3 \times 10^{11}\text{Hz}$  at  $3 \times 10^{15}\text{Hz}$ );
  - ionizing radiation;
  - ultrasound.



## 2.4. SAFETY PLATES AND SYMBOLS

Labels with safety symbols and/or messages are attached to the vacuum cleaner and packaging. At these pages their exact location and nature of the hazard is indicated.

### **WARNING**

The nameplates and symbols below are indicative and may not be applicable to the models in the vacuum cleaner series described. The presence of each symbol will vary according to the specifications of the series and/or individual model.

### **WARNING**

Ensure that all safety messages are legible. The user is required to immediately replace any safety plates that become illegible due to wear and tear or damage.

Clean them using a cloth, soap and water. Do not use solvents, naphtha or gasoline. Replace damaged plates by requesting them from DEPURECO.

If a nameplate is on a part that is being replaced, make sure a new nameplate is attached to the new part.



This sticker indicates that the device can vacuum dust up to class M.



This sticker indicates that the device can vacuum dust up to class H.



This sticker indicates the manual filter cleaning system.



This sticker warns of the danger of crushing limbs.



This sticker indicates that the vacuum cleaner is grounded.



Hexagon Ex - ATEX Directive 2014/34/EU  
This sticker indicates that the vacuum cleaner is certified for use in hazardous areas (for dedicated models and versions).



This sticker indicates that the device can vacuum combustible dust in areas not classified as ATEX (for dedicated models and versions).

## **WARNING**

Read the operation and maintenance manual carefully before using the vacuum cleaner or performing maintenance work.

It is strictly forbidden to remove the safety labels on the vacuum cleaner and/or its components and packaging.

DEPURECO accepts no responsibility for the safety of the vacuum cleaner if this prohibition is not observed.



## 2.5. RESIDUAL RISKS

DEPURECO recommends strict adherence to the instructions, procedures and recommendations in this manual and to current safety regulations. In addition, DEPURECO recommends the use of the prescribed protective equipment, either integrated into the vacuum cleaner or individual.

In this view, the residual hazards analyzed that are present on the vacuum cleaner and/or its components may be:

### **Electrical hazards in maintenance due to the need to work under voltage**

Pursuant to Legislative Decree 81/08-Articles 80 to 87-it is forbidden to work under voltage, except for the exceptions stipulated in that decree.

### **Risk of misuse in the presence of liquid, deflagrating and flammable substances**

The vacuum cleaner should not be used in an environment containing liquid substances or in the form of liquids that can vaporize at room temperature, flammable dusts, gases.

### **Risks of operating in a humid environment**

Comply with the limits given in this manual in Section 1.8 "Allowable Environmental Conditions."

### **Risk of misinterpretation of safety pictograms**

With reference to the analysis of risks and their identification, DEPURECO has installed hazard labels from the regulations on graphic symbols on the vacuum cleaner.

The user is required to immediately replace safety plates that become illegible due to wear and tear or damage.

## 2.6. DIRECTIVES APPLIED

The following guidelines apply to the vacuum cleaner described in this manual:

- 2006/42/EC - Machinery Directive.
- 2014/30/EU - Electromagnetic compatibility directive.
- 2011/65/EU - ROHS - Directive on the restriction of the use of certain hazardous substances in electrical and electronic equipment.
- 2014/35/EU - Low Voltage Directive.
- 2014/34/EU - ATEX Directive (for ATEX models and versions).

Regulatory references, including mandatory requirements, are managed in the Quality Management System and archived at DEPURECO.



### 3. HANDLING, UNPACKING AND INSTALLATION SECTION

#### 3.1. HANDLING

The instructions that follow also indicate the steps to be taken in case the vacuum cleaner should be newly packed or unpacked for later transport.

Packaging size:

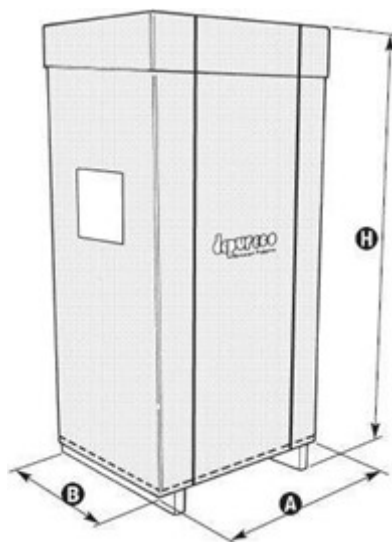

	MU.	A	B	H
MINIAIR 2V - MINIAIR 2V Z2-22	[cm]	80	60	170
XM20 AIR JC	[cm]	80	60	170

Lifting and subsequent handling of the vacuum cleaner should be done only by a forklift of appropriate capacity for the weight.

When moving with the forklift, lift the load 200 mm off the ground and swing backward.

When lifting loads, take into account the height of the environment in which you are working.

Before starting the movement make sure the passage area is clear and that there are no moving objects on the package. For lifting and handling, apply current accident prevention laws and normal forklift driving instructions.

Move the device only at walking pace and, on sloping paths, in twos if necessary.



## 3.2. UNPACKING

To perform unpacking of the machine:

- Cut the fixing tapes.

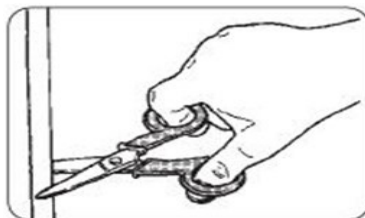

- Remove the retainers with the help of a hammer and screwdriver.

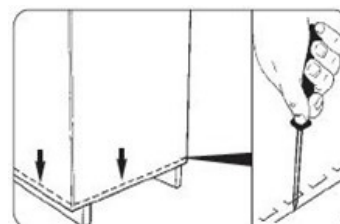

- Unwrap the cardboard packaging.



- Remove all fasteners provided by the manufacturer at packing stage using appropriate tools.

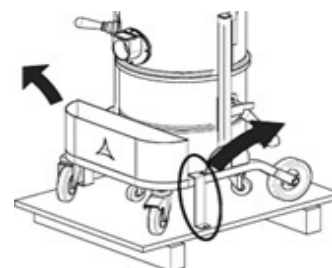

Remove the machine from the support platform by helping yourself with a ramp of suitable capacity and leading the vacuum from the handle.

Conduct these operations on flat, horizontal surfaces. The load-bearing capacity of the support surface must be adequate for the weight of the machine.

Provide ample space around the plant in order to operate with freedom of movement and to allow easy operations by operators in anticipation of future maintenance work.

### **WARNING**

Depureco is not liable for any damage caused to the machine during lifting if the proper equipment is not used.

### **WARNING**

For possible subsequent transport, the vacuum cleaner should be anchored to the support platform by means of a locking system similar to that described above.

### **WARNING**

Dispose of packaging materials in accordance with current legislation.



### 3.3. INSTALLATION

#### **⚠ WARNING!**

The following must be complied with before installing the vacuum cleaner  
In section 2.2 "Safety requirements."

#### **⚠ WARNING!**

Before installing the vacuum cleaner, it is necessary to make a careful prior visual inspection in order to detect any damage incurred during transportation.

If one or more components are found to be damaged, it is essential not to proceed further with the installation and to report the anomaly found to Depureco, agreeing with it on the action to be taken.  
The machine arrives with the planned filter unit already installed.

- Insert the hose with the connector into the appropriate suction inlet (Part 7, Section 1.2).
- Insert the desired accessory for the suction type from the opposite side of the hose.

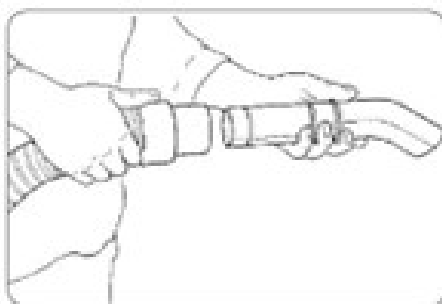

*Note: The hose with its terminals and suction accessories are not included in the STANDARD equipment. Contact your dealer (or DEPURECO) for information regarding the different types of OPTIONAL accessories that can be used for this specific vacuum cleaner model.*

Verify that the air supply line matches the required pressure for the vacuum cleaner.

- The hose is properly inserted and locked into the suction nozzle.
- The debris collection container must be present and locked onto the vacuum cleaner.
- No dust escapes when replacing accessories.





## 4. OPERATION SECTION

### 4.1. COMMAND DESCRIPTION

#### **WARNING**

- Before proceeding to use the vacuum cleaner, it is necessary to comply with what is stated in Section 2.2 "Safety Requirements."
- Only authorized personnel who have read these operating and maintenance instructions are allowed to use the vacuum cleaner. The user of the equipment and the maintenance technician who carry out permissible work on the vacuum cleaner must receive appropriate education, information and training, as required by current labor safety laws, and use for the various operations, the prescribed personal protective equipment (PPE), such as safety footwear, gloves, goggles, mask, etc. The user must observe the current regulations for sucked materials and their disposal.
- Before a new work cycle, the personnel in charge must verify that the normal safe operating conditions of the vacuum cleaner and, in particular, the safety devices and protective guards involved in the operation are ensured.

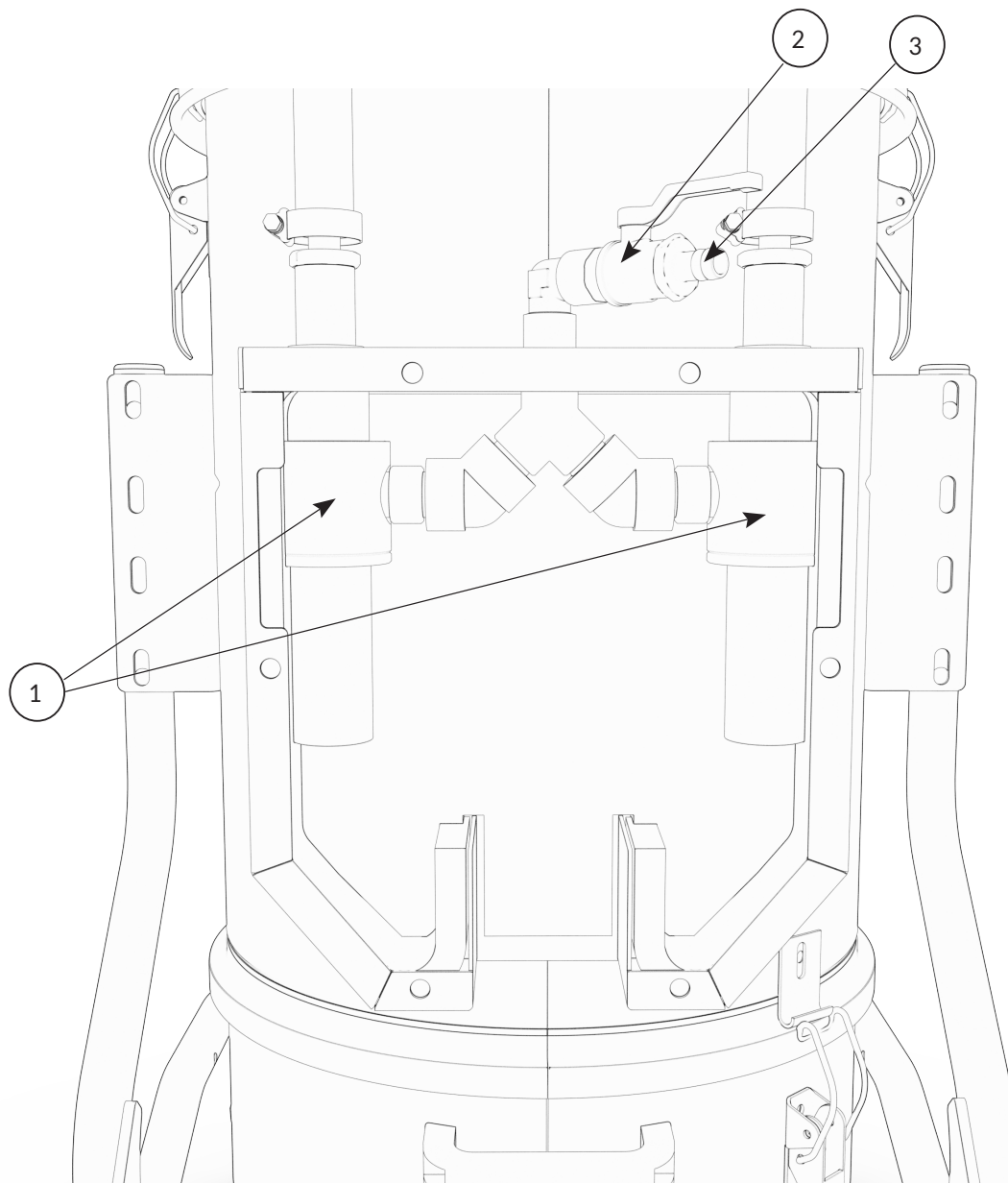



## 4.2. DUTY CYCLE

Before starting the aspiration, it is necessary to comply with what is stated in Section 2.2 "Safety Requirements." Specifically:

- Make sure the compressed air supply hose is properly connected to the machine's inlet valve.
- Ensure that the suction arm or hose is properly inserted and locked into the suction nozzle.
- Ensure that the debris collection container (if any) is properly positioned and locked under the vacuum cleaner chamber.

### **ATTENTION!**

To move the vacuum cleaner, use the handles provided (Part 8, Section 1.2).

### **WARNING**

Do not move the vacuum cleaner while it is in operation.

To start suction, proceed as follows:

- Lock the vacuum cleaner by means of the lever on the turning wheel, as shown in the figure.

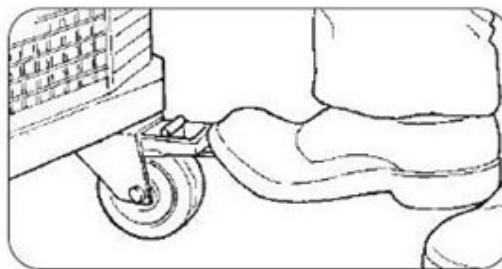

- Grip the end of the hose with the chosen suction attachment or place the end of the suction arm at the suction point.
- Connect the pneumatic suction hose to the FR unit on the vacuum cleaner at one end, and to the pneumatic supply valve located upstream of the vacuum cleaner at the other end.
- Open the air supply valve and make sure the pressure gauge on the FR unit indicates an inlet pressure between 6 and 8 bar
- Start the vacuum
- To turn off the vacuum cleaner, close the air supply valve located upstream of the vacuum cleaner.

### **WARNING**

Never disconnect the air supply hose from the vacuum cleaner for any reason without first closing the air supply valve located upstream of the vacuum cleaner.



## ALL MODELS

### **WARNING**

During operation, avoid stepping on, crushing, pulling, or damaging any components. If machine parts need to be replaced, replace them only with parts of the same type as the original ones installed. Replacement must be performed by the manufacturer or by equally qualified personnel.

Those responsible for plant safety must ensure that:

- Any improper use or maneuvering be avoided.
- Safety devices are not removed or tampered with.
- Regular maintenance work is carried out.
- Machine parts (attachments, drilling, etc.) are not modified for any reason to fit additional devices.
- Only original Depureco spare parts should be used.
- Be prevented from rolling or bending the hose during the suction operation.

### **WARNING**

If dust is escaping from the vacuum cleaner head, the filter may have broken. In this case, the vacuum cleaner should be stopped immediately.

## 4.3. AIR SPEED CONTROL

### ALL MODELS

- Check the hose and/or suction accessory for clogging and eliminate the cause of clogging.
- Perform a filter cleaning cycle (section. 4.4).
- Stop work and replace filters.

### **WARNING**

Do not use the vacuum cleaner with a clogged filter.

## 4.4. FILTER CLEANING CYCLE

It is advisable to perform a filter cleaning cycle every 20 minutes of use or if you experience a drop in performance.

To perform a filter cleaning cycle:

### MINIAIR 2V - MINIARI 2V Z2-Z22

- Turn off the machine.
- Lift and then vigorously lower the lever (Part.6 section 1.2) to shake the internal filter.

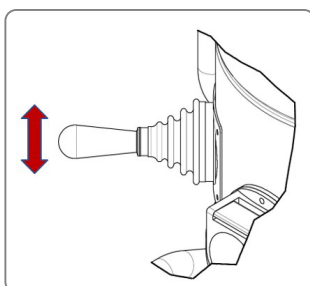



## XM 20 AIR JC

This model is equipped with the JetClean® cleaning system.

The system works due to the pressure difference between the atmosphere inside and outside the vacuum cleaner causing the dust to detach from the filter fabric of the cartridge, without the need to turn off the vacuum cleaner.

- With the vacuum cleaner turned on, lift the flap (Part 12, Section 1.2) located on the intake vent.

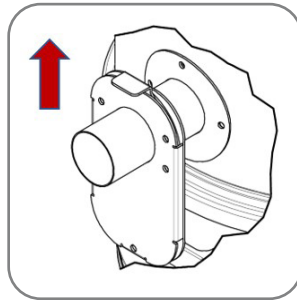

- Open and quickly release the disc (Part 11, Section 1.2), and repeat the procedure at least three times.

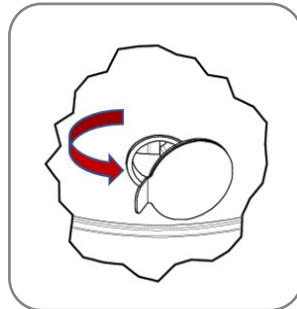

- Lower the damper and resume normal use.

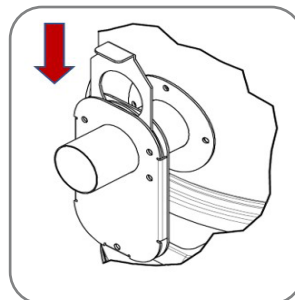

## ALL MODELS

If the vacuum cleaner does not work properly after filter cleaning, the main filter may need to be replaced (see dedicated chapter). If the vacuum is not significantly reduced by replacing the filter, it means that another problem is present (see chapter "If something is not working").

### **WARNING**

Do not use the vacuum cleaner with a clogged filter.



## 4.5. EMPTYING THE CONTAINER

### **WARNING**

The container should not only be emptied when full, but also at the end of each work cycle and before being transported. During this operation, use the appropriate PPE (gloves, dust mask, goggles, etc.).

### **WARNING**

Depending on the type of material vacuumed and the amount, the debris container/Endless Bag should be checked periodically and overfilling should be avoided.

### **WARNING**

Before proceeding with emptying, turn off the machine and lock the vacuum cleaner by means of the lever located on the turning wheel (Page 28)

## XM 20 AIR JC

- Unlock the container by releasing the locking hooks (Part 13, Section 1.2).
- Pull the container (Part.4 section 1.2) out from under the chamber.
- Empty the container into the receptacle intended for waste disposal in accordance with the laws of the country of use.



If a plastic bag is used for debris collection, proceed as follows for replacement:

- After removing the container, tie the bag, pull it out, and insert a new bag.



### **WARNING**

If the container weighs more than 15 kg, you need to get help from another person.

### **WARNING**

Waste disposal must be in accordance with the laws in force in the country where the vacuum cleaner is used - for Italy Legislative Decree 152/2006 as amended.

### **WARNING**

In the case of dust extraction that may give rise to self-ignition phenomena, the collection bin must be emptied immediately after each activity.

This precaution should also be taken in the case of aspiration of dust of different types whose mixture may give rise to exothermic reactions.



## MINIAIR 2V - MINIARI 2V Z2-Z22

- Unlock the container by raising the appropriate lever (Part 3, Section 1.2).

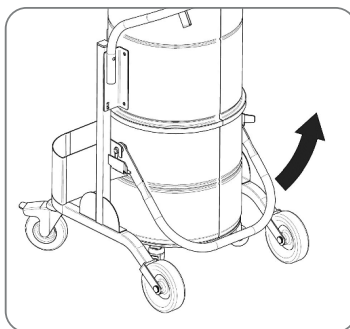

- Pull the container (Part.4 section 1.2) out from under the chamber.

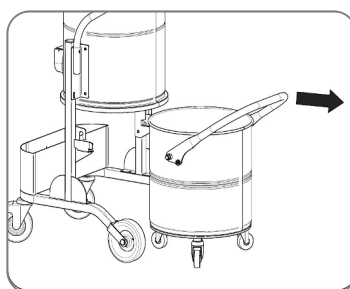

- Empty the container into the receptacle intended for waste disposal in accordance with the laws of the country of use.



If a plastic bag is used for debris collection, proceed as follows for replacement:

- After removing the container, tie the bag, pull it out, and insert a new bag.



### **WARNING**

If the container weighs more than 15 kg, you need to get help from another person.

### **WARNING**

Waste disposal must be in accordance with the laws in force in the country where the vacuum cleaner is used - for Italy Legislative Decree 152/2006 as amended.



## **⚠** **WARNING**

In the case of dust extraction that may give rise to self-ignition phenomena, the collection bin must be emptied immediately after each activity.

This precaution should also be taken in the case of aspiration of dust of different types whose mixture may give rise to exothermic reactions.

### **4.6. INSERTING AND LOCKING THE CONTAINER**

#### **XM 20 AIR JC**

- Insert the container under the vacuum cleaner by aligning the locking hooks (A) with the strikers (B) located on the filter chamber.

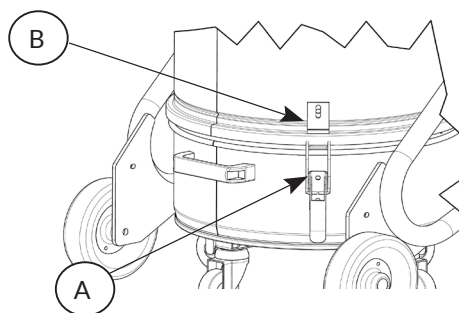

- Raise the container toward the chamber and lock the locking hooks.

## **⚠** **WARNING**

**Danger of crushing upper limbs!**

**Never insert your hands between the container and the vacuum cleaner during the clamping operation.**

#### **MINIAIR 2V - MINIARI 2V Z2-Z22**

- Insert the container under the vacuum cleaner, holding the lever up, until it comes to a complete stop against detentions.

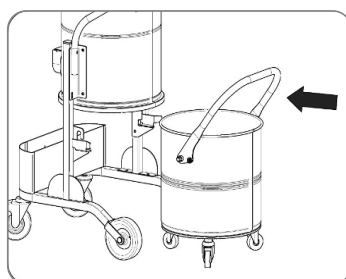

- Check that the pins (D) on both sides of the container are aligned with the slots (E) of the guides.

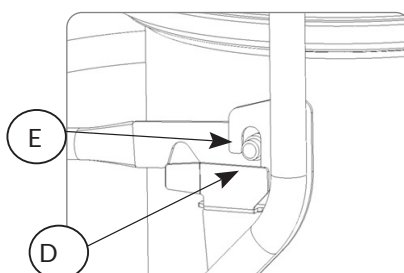



- Lower the container locking lever completely and with both hands.

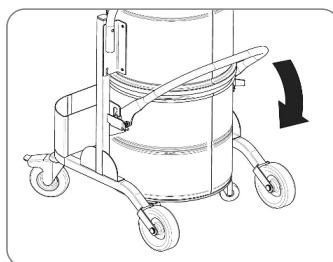

## **WARNING**

Danger of crushing upper limbs!

Never insert your hands between the container and the vacuum cleaner during the clamping operation. Perform the container locking operation by operating the appropriate lever with **BOTH HANDS**.

## **4.7. STORAGE - DECOMMISSIONING**

Remove the filter and clean it, empty the debris collection container, and store the vacuum cleaner in a place sheltered from the weather with temperatures between -15 °C and 40 °C, covering it with a nylon cloth so as to prevent dust accumulation.



## 5. MAINTENANCE SECTION

### **WARNING**

Extraordinary maintenance of the vacuum cleaner should be carried out only by specialized technicians recognized by the DEPURECO dealer.

### 5.1. INFORMATIONAL NOTES

Maximum vacuum cleaner reliability and minimum maintenance cost are the result of a planned and scrupulously followed maintenance and inspection program throughout the life of the vacuum cleaner. It is important to:

- Strictly adhere to the established maintenance time intervals and cadence the maintenance work according to the specific needs in relation to the production cycle of the vacuum cleaner.
- Always use tools that are in perfect condition and specially made for the task at hand; the use of unsuitable and inefficient equipment can cause serious damage.
- Any other work that may be necessary to eliminate faults or malfunctions must be expressly authorized by the manufacturer.
- For major repairs, it is advisable to contact the authorized dealer whose trained staff, equipped with all the technological experience of the original factory construction, is always on call and able to take timely action.
- Disassembly, cleaning, and maintenance of the vacuum cleaner by the user should be carried out whenever possible without leading to hazards to maintenance personnel and third parties. Suitable precautionary measures include decontamination before disassembly, measures for filtered forced ventilation of the room where the unit is disassembled, cleaning of the maintenance area, and suitable personal protective equipment.
- The manufacturer or qualified person should perform, at least once a quarter (or more frequently depending on the working cycle and conditions of use), an inspection to the filters checking that they are not damaged, also check the proper functioning of the control devices.

### **WARNING**

Following maintenance or repair work, all contaminated items that cannot be satisfactorily cleaned should be placed in waterproof bags and disposed of in accordance with applicable laws.

### 5.2. GENERAL SAFETY STANDARDS

### **WARNING**

All maintenance, repair, or cleaning work must be performed with the power turned off. Appropriate PPE (protective clothing, goggles, and/or gloves, etc.) must be worn depending on the task at hand.

Affix a sign on the vacuum cleaner indicating:

**"MACHINE UNDER MAINTENANCE DO NOT START"**

Before resuming service, recheck the entire system in accordance with the start-up procedures. Perform a few test cycles after each maintenance operation to check that the machine is working properly. Failure to observe these precautions may result in serious injury to personnel. Maintenance work must be performed by technicians who are skilled and trained in the specific areas, which for this machine are:

- Mechanical maintenance.

It is the specific duty of the **Head of Security** Ensure the professionalism and competence of the aforementioned people.



Before starting a maintenance task, the Safety Officer must:

- Have the work area cleared of outsiders.
- Make sure the necessary tools are within reach of the maintainer and are in good condition.
- Ensure that the maintenance worker has the necessary personal protective equipment for the specific operation (gloves, goggles, shoes, mask, etc.).
- Ensure that the maintainer has carefully read the instructions in this manual and is fully familiar with the operation of the vacuum cleaner and its components.
- Check for sufficient lighting and provide 24-volt powered portable lamps if necessary.

Before beginning any maintenance work, the maintenance technician must disconnect all power sources, set the vacuum cleaner to the safety lock position, and disconnect the compressed air supply (where applicable).

### **WARNING**

If it is absolutely necessary to operate with the power on, when required by D. Lgs. 81/08, the maintainer must keep a safe distance, have stop buttons within reach, and never put hands in the discharge volume. At the end of the intervention and before resuming service, the maintainer must recheck the functionality of safety devices and the integrity of protections.

### **WARNING**

After each maintenance work, the Safety Officer is obliged to ensure the safe condition of the vacuum cleaner and its protective devices.

Before each work shift:

- Check the integrity of the safety symbols (pictograms) attached to the vacuum cleaner.
- Check that the debris collection container is empty and properly locked under the vacuum cleaner.
- Verify proper filter efficiency by checking the indicator light or vacuum gauge.
- Check the integrity of the suction hose and accessories to be used.

### **WARNING**

The hose, if perforated, decreases the suction power and disperses dust into the air.



### 5.3. PRIMARY FILTER REPLACEMENT

#### **WARNING**

Wear appropriate PPE (dust mask, latex gloves, goggles, etc.).

For the filter replacement primary Operate as follows:

- Turn off the machine.
- Unplug the vacuum cleaner from the power source.

#### **MINIAIR 2V - MINIARI 2V Z2-Z22**

- Remove the container as described in section 4.5.
- From the underside of the filter chamber, unhook the clip and slide out the pin securing the cage to the filter shaker lever.

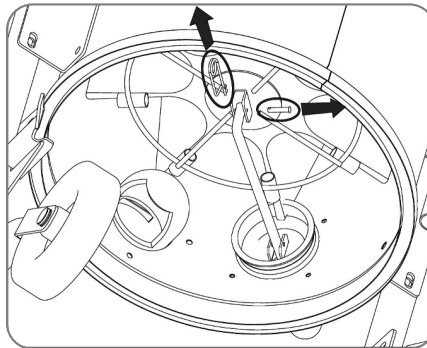

- Unlock the two locking hooks (C) of the head on the filter chamber from both sides.

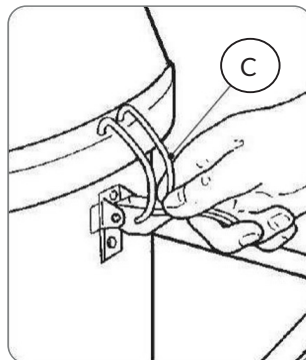

- Remove the head and place it on the workbench.
- Slide out the filter (F) and place it on the workbench.





- Loosen the retaining clamp (H) and detach the filter from its holder.

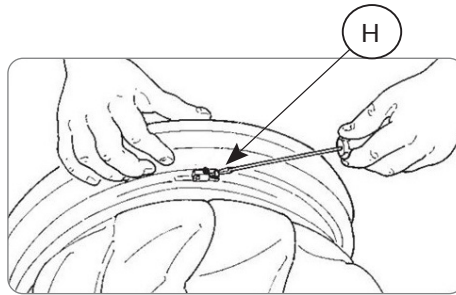

- Using scissors, cut the tapes on the bottom of the filter that secure it to the cage.

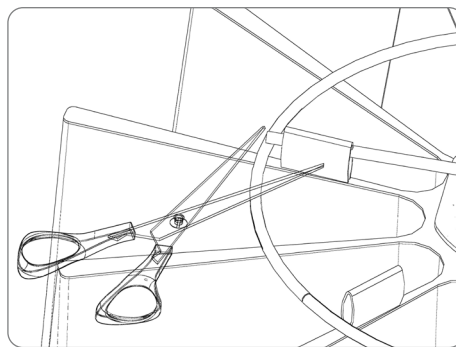

## XM 20 AIR JC

- Unlock the two locking hooks (C) of the head on the filter chamber from both sides.

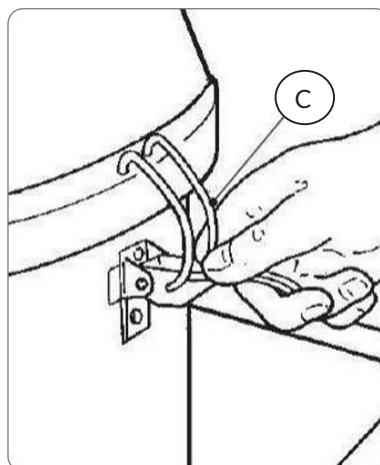

- Remove the head and place it on the workbench.



- Using the appropriate equipment, unscrew the screws securing the cartridge and slide it out from inside the filter chamber.

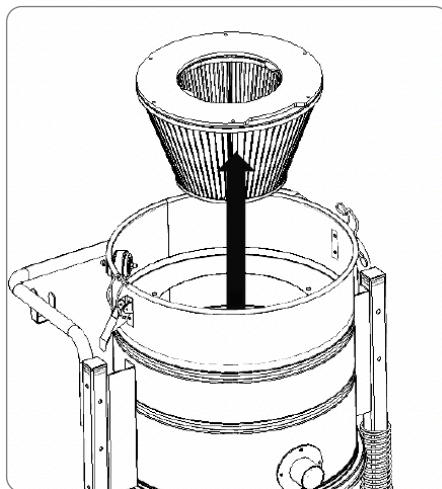

#### ALL MODELS

### **WARNING**

Remove the filter, place it inside a plastic bag, close it and dispose of it according to current laws for the type of material sucked in.

** USE ONLY ORIGINAL DEPURECO FILTERS!**

** TO REASSEMBLE THE FILTER OPERATE THE FOLLOWING OPERATIONS.**



## 5.4. HEPA FILTER REPLACEMENT

### **WARNING**

Wear appropriate PPE (dust mask, latex gloves, goggles, etc.).

For the filter replacement HEPA Operate as follows:

- Turn off the machine.
- Unplug the vacuum cleaner from the power source.

### HEPA FILTER OPTION

#### ALL MODELS

- Unlock the two locking hooks (C) of the head on the filter chamber from both sides.

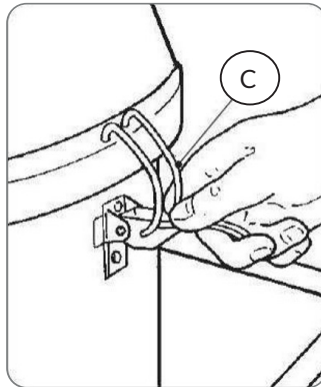

- Remove the head and turn it upside down on the workbench.
- Unscrew the retaining nut (L) of the HEPA cartridge.

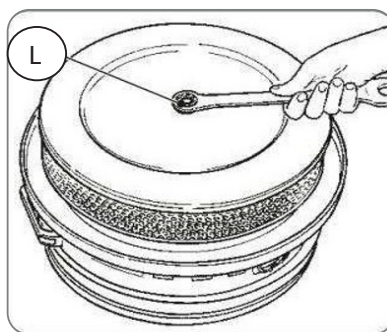

- Remove the HEPA filter from the head.

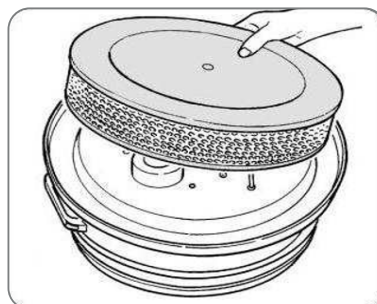



---

## ALL MODELS

### **WARNING**

Remove the HEPA filter, place it inside a plastic bag, close it, and dispose of it according to current laws for the type of material vacuumed.

** USE ONLY ORIGINAL DEPURECO HEPA FILTERS!**

** TO REMOVE THE HEPA FILTER, DO THE FOLLOWING OPERATIONS.**



## 5.5. IF SOMETHING DOESN'T WORK

ANOMALY FOUND	POSSIBLE CAUSE	RECOMMENDED REMEDY
The vacuum cleaner does not start.	Lack of power supply.	<ul style="list-style-type: none"><li>• Check for compressed air in the main line.</li><li>• Check that the fuel line is intact.</li><li>• Open the compressed air valve on the machine.</li><li>• Contact DEPURECO technical assistance.</li></ul>
Irregular suction.	Clogged filter.	<ul style="list-style-type: none"><li>• Shake the filter.</li><li>• If it is not enough, replace it.</li></ul>
Dust leakage from the vacuum cleaner.	<ul style="list-style-type: none"><li>• Filter washed out.</li><li>• Filter not suitable for the type of material to be vacuumed.</li></ul>	<ul style="list-style-type: none"><li>• Replace the filter.</li><li>• Mount the filter suitable for the material to be vacuumed.</li></ul>
Excessively noisy engines.	Failed engines.	Contact DEPURECO technical assistance.

## 5.6. SCRAPPING

### **WARNING**

In case of scrapping, to avoid damage to the environment, all vacuum cleaner components, shall be disposed of responsibly, in appropriate landfills following the relevant national regulations. Vacuum cleaner parts consisting of plastic material, aluminum, steel, may be recycled by delivering them to the appropriate centers.

The crossed-out bin symbol on the label on the equipment indicates that it complies with the regulations on waste electrical and electronic equipment. Abandoning the equipment in the environment or improperly disposing of it is punishable by law.

RAEE REGISTER ENTRY NO. IT18090000010711

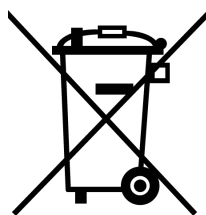



## MAINTENANCE LOG

MODEL: \_\_\_\_\_

MATRICOLA: \_\_\_\_\_

DELIVERY DATE: \_\_\_\_\_

ENTERPRISE: \_\_\_\_\_

ADDRESS: \_\_\_\_\_

N. \_\_\_\_\_

CITY: \_\_\_\_\_

ZIP CODE: \_\_\_\_\_

BUSINESS SECTOR: \_\_\_\_\_

PHONE: \_\_\_\_\_

RESPONSIBLE: \_\_\_\_\_

TIMBERS: \_\_\_\_\_

### Depureco Industrial Vacuums Srl

Company subject to management and coordination COFISE spa

Via Venezia, 32 - 10088 Volpiano (TO)  
**Tel.** +39 011 98.59.117  
**Fax.** +39 011 98.59.326

**www.depureco.com**  
depureco@depureco.com  
depureco@documentipec.com

**C.F. and P.I.** 02258610357 - **Capital stock:** € 25,000 i.v.  
Turin Business Register - **R.E.A.** TO-1149668  
Registration **WEEE** No. IT18090000010711



**INTERVENTION 1:**

**DATE:**

TECHNICAL ASSISTANCE:

TYPE OF INTERVENTION:

**INTERVENTION 2:**

**DATE:**

TECHNICAL ASSISTANCE:

TYPE OF INTERVENTION:

**Depureco Industrial Vacuums Srl**

Company subject to management and coordination COFISE spa

Via Venezia, 32 - 10088 Volpiano (TO)  
**Tel.** +39 011 98.59.117  
**Fax.** +39 011 98.59.326

**www.depureco.com**  
depureco@depureco.com  
depureco@documentipec.com

**C.F- and P.I.** 02258610357 - **Capital stock:** € 25,000 i.v.  
Turin Business Register - **R.E.A.** TO-1149668  
Registration **WEEE** No. IT18090000010711



**INTERVENTION 3:**

**DATE:**

TECHNICAL ASSISTANCE:

---

---

---

---

---

---

---

---

TYPE OF INTERVENTION:

---

---

---

---

---

---

---

---

**INTERVENTION 4:**

**DATE:**

TECHNICAL ASSISTANCE:

---

---

---

---

---

---

---

---

TYPE OF INTERVENTION:

---

---

---

---

---

---

---

---

**Depureco Industrial Vacuums Srl**

Company subject to management and coordination COFISE spa

Via Venezia, 32 - 10088 Volpiano (TO)  
**Tel.** +39 011 98.59.117  
**Fax.** +39 011 98.59.326

**www.depureco.com**  
depureco@depureco.com  
depureco@documentipec.com

**C.F. and P.I.** 02258610357 - **Capital stock:** € 25,000 i.v.  
Turin Business Register - **R.E.A.** TO-1149668  
Registration **WEEE** No. IT18090000010711

